

DOC.NR.	REV	DATE	BY	DESCRIPTION
E0047327	-	12-1-2016	PB	COPY FROM ACAD. OLD REV WAS B
TBBB033514	A	18-1-2023	DK	SOURCE CODE AND TYPE PLATE STICKER ADDED

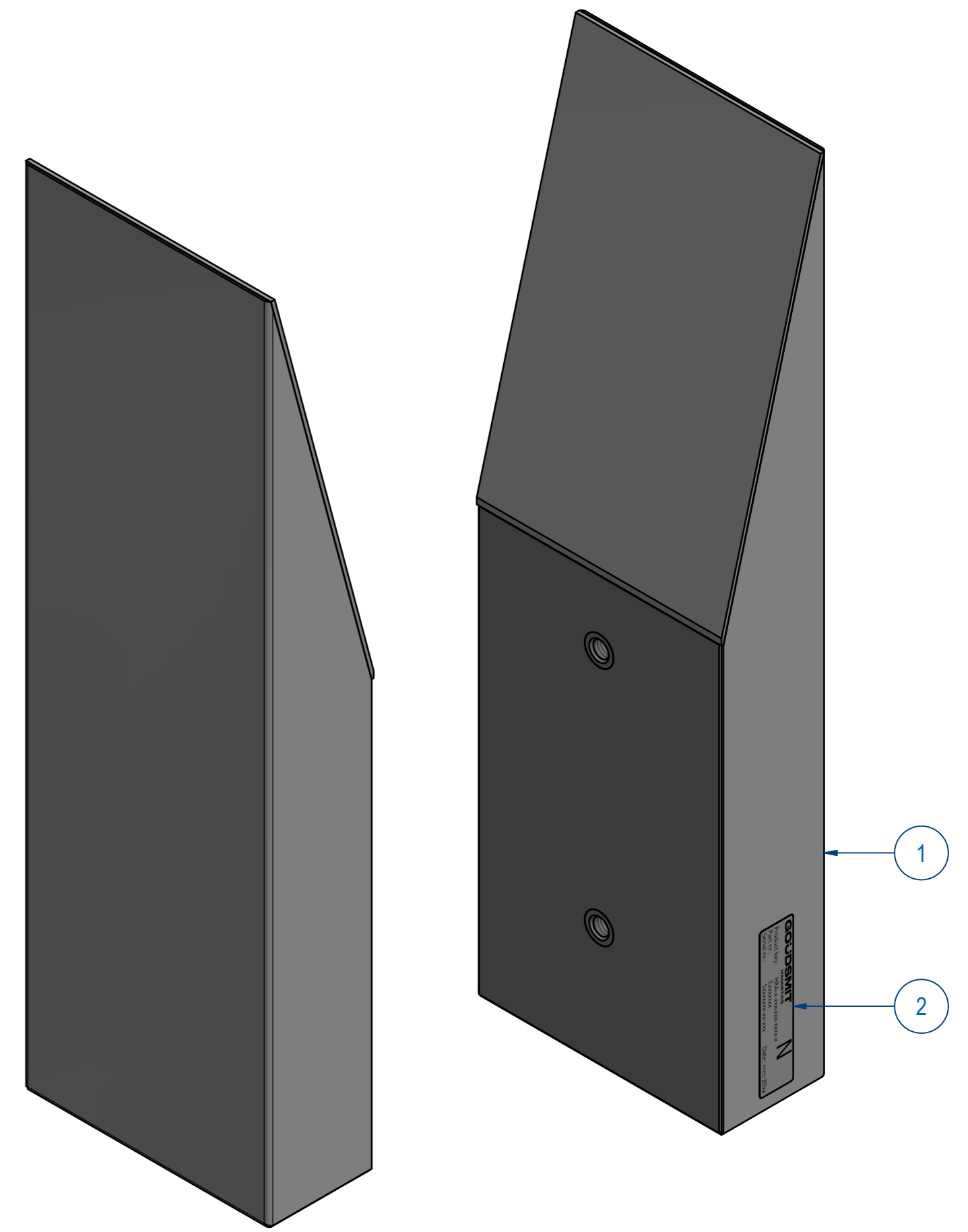
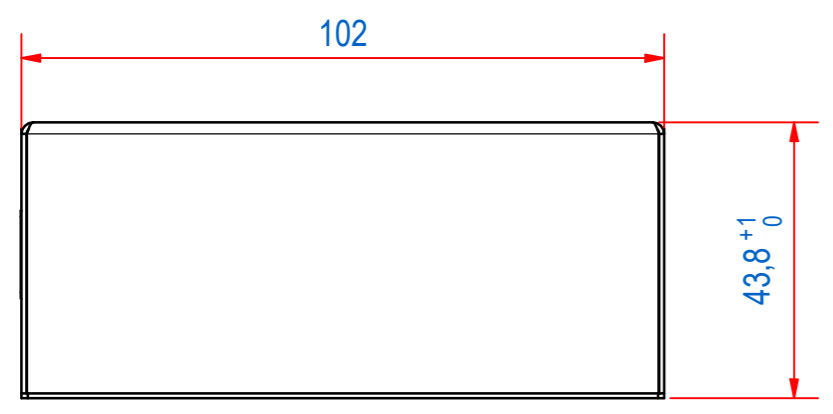
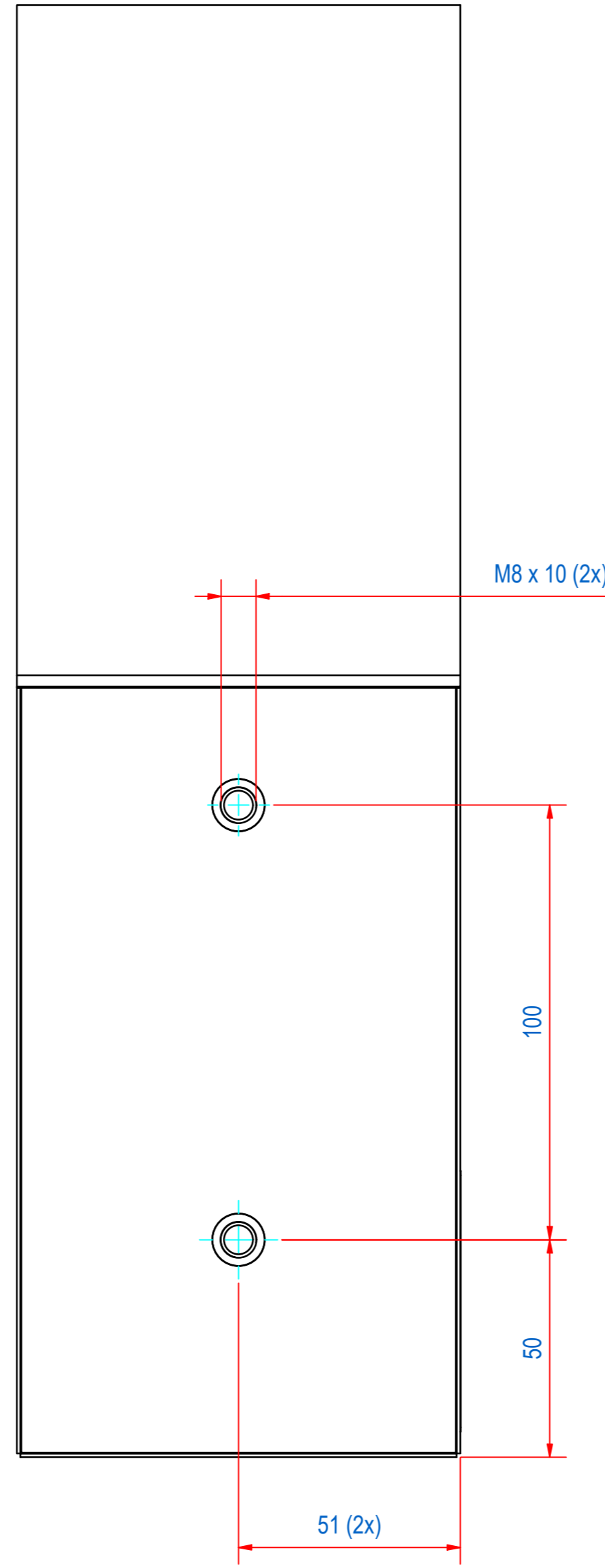
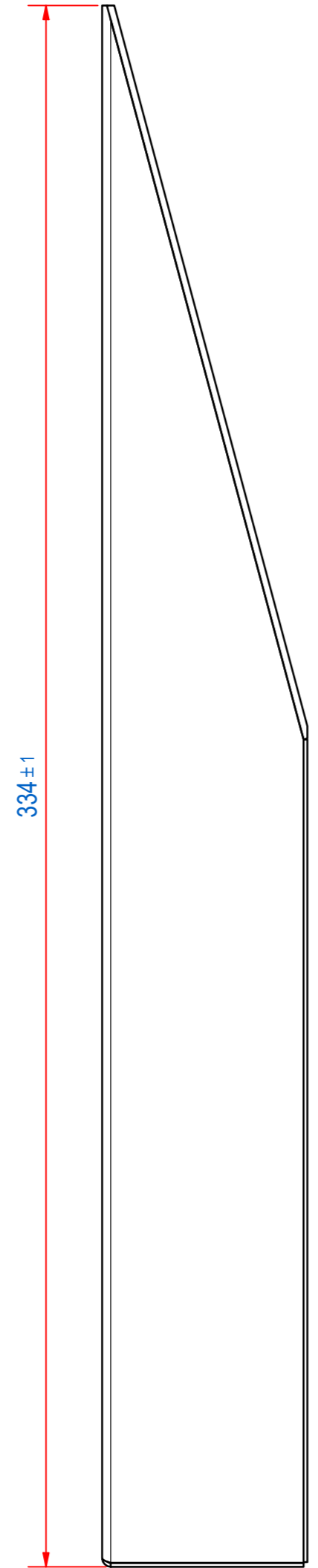
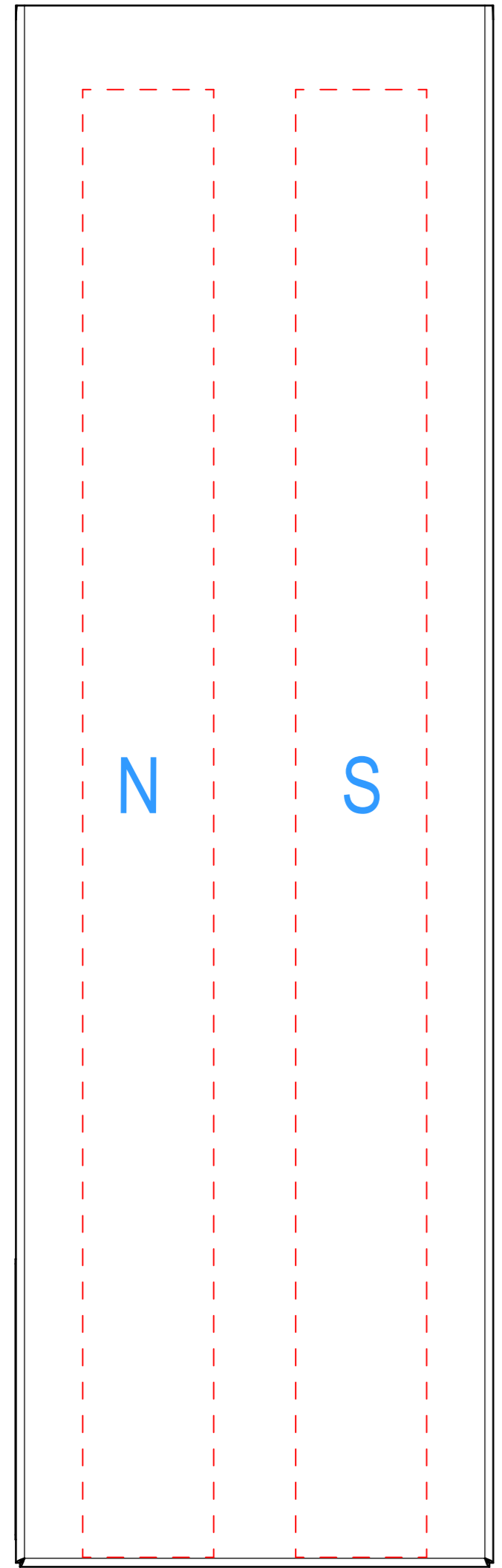

ITEM	QTY	PART NUMBER	DESCRIPTION	Dimensions
2	1	E0156615	HRA-TYPE PLATE STICKER	
1	1	E0157384	HRA-WELD ASSY	

RAW MAT.	Quantity	Material Number	Material Description	Length (mm)	Width (mm)
	1				

Sheet: <b>A2</b> Drawn: <b>PB</b> Date: <b>12-1-2016</b> Spare part: <b>False</b> Quick search: <b>TBBB14</b>	Extra info: <b>MAGNETIC RAIL REINFORCED</b> Weight (kg): <b>5,4</b> Source: <b>MC-C</b>	General tolerance: <b>ISO 2768 - mK</b> Drawn according: <b>ISO268; ISO1101; ISO2553</b> Status: <b>Standard</b> Customer reference number: Document number: <b>TBBB033514</b> Doc.Rev: <b>A</b> Part number: <b>TBBB033514</b> Rev: <b>A</b>
---	--	--

Description: <b>HRA-F-102x44-BB-0335-R-B</b>	© All rights reserved. Reproduction is not permitted without written permission of GOUDSMIT Magnetic Systems BV
--	---