

REV	DATE	BY	DESCRIPTION
-	19-6-2014	PB	NEW VAULT, NEW REVISION. NOTHING CHANGED. OLD REV WAS A
A	7-9-2022	PB	WELD ASSY ADDED.
B	18-1-2023	DK	STICKER AND SOURCE CODE ADDED

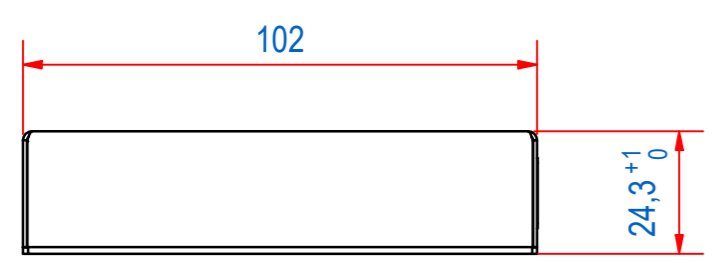
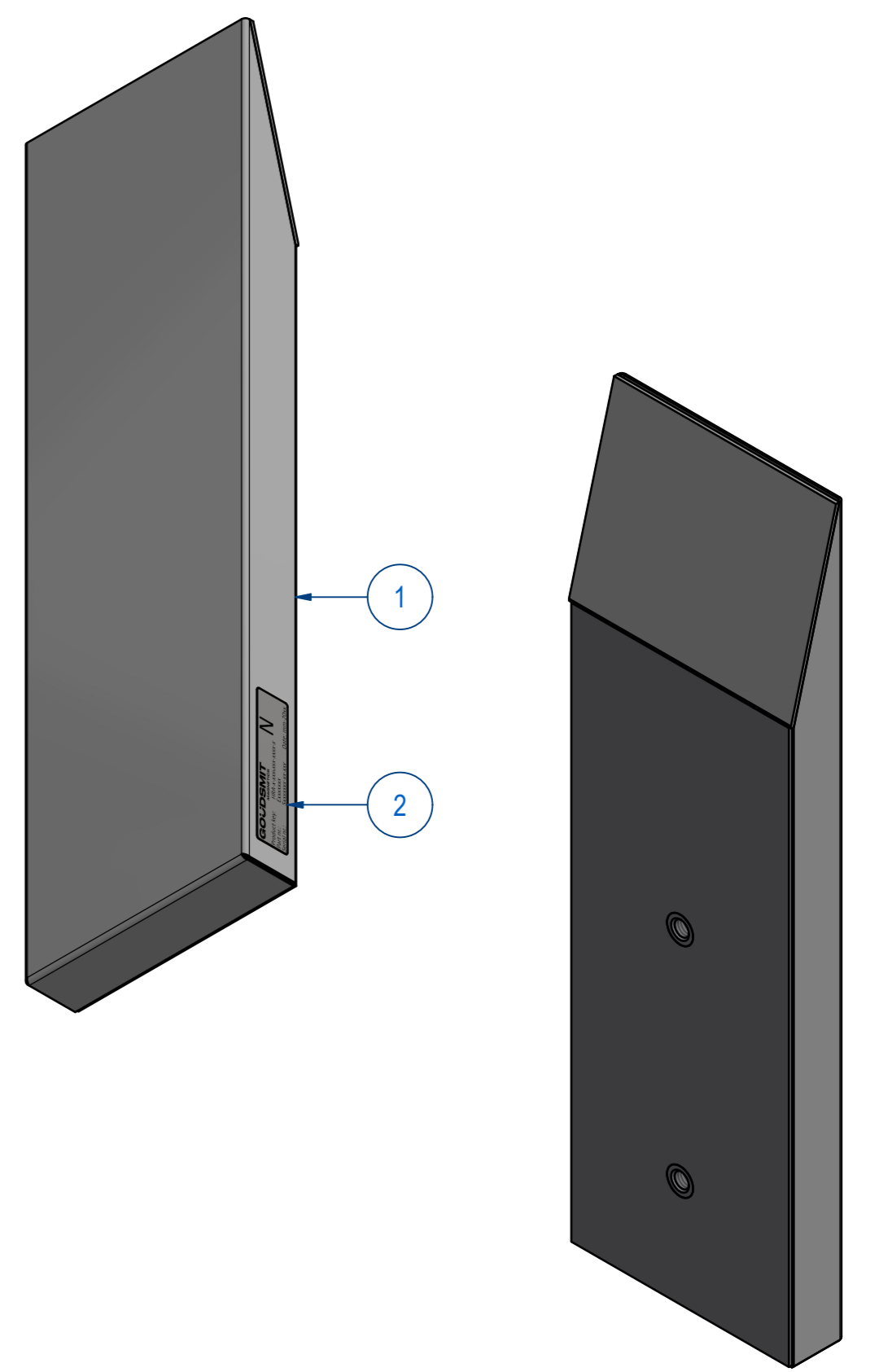
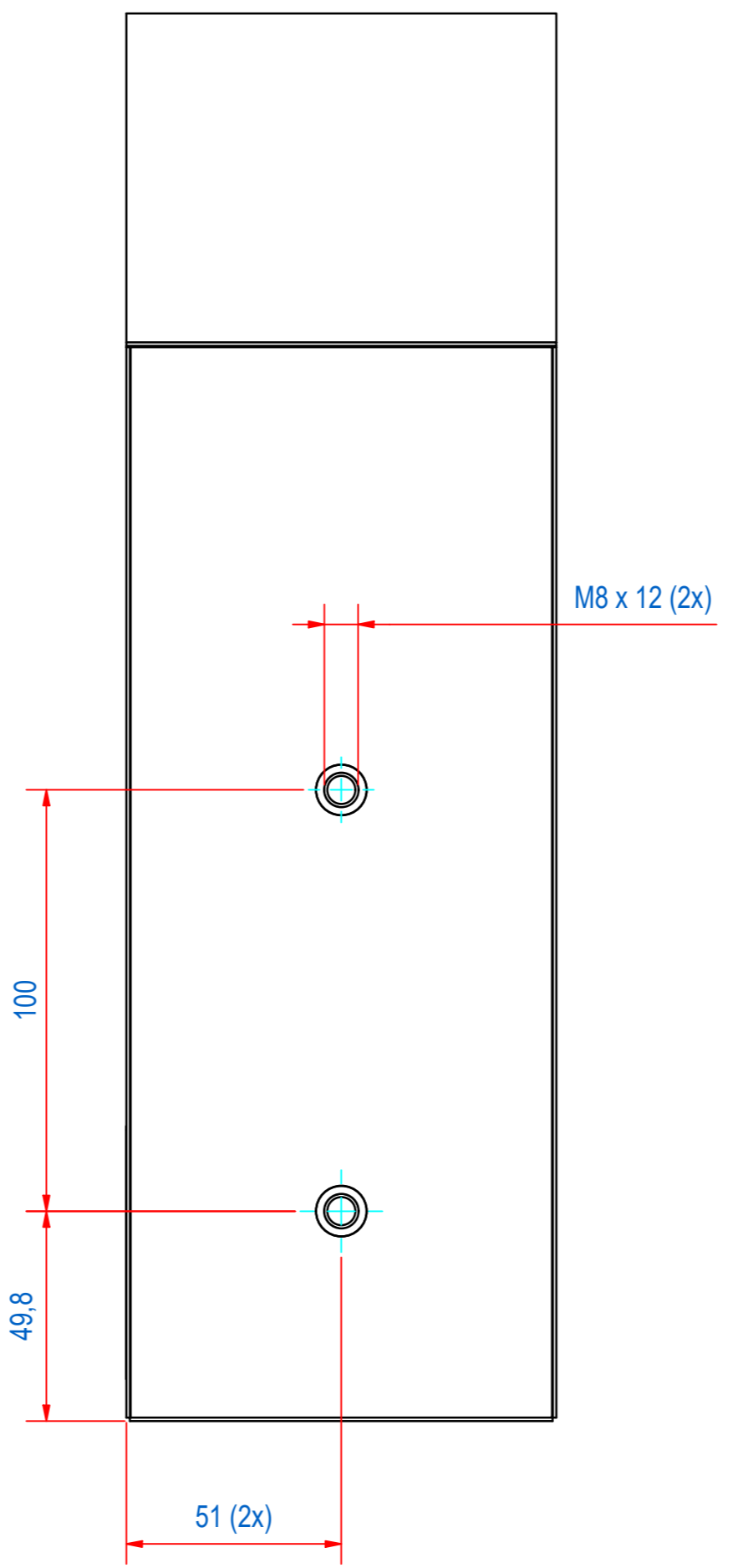
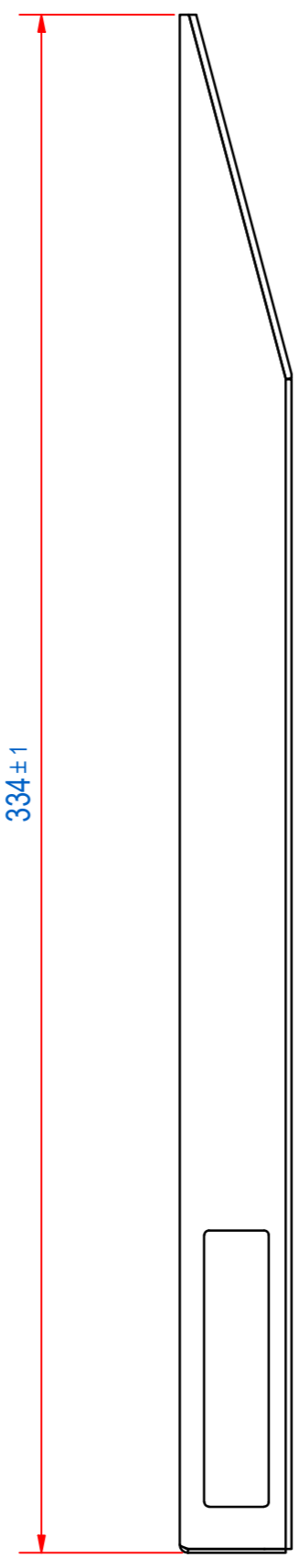
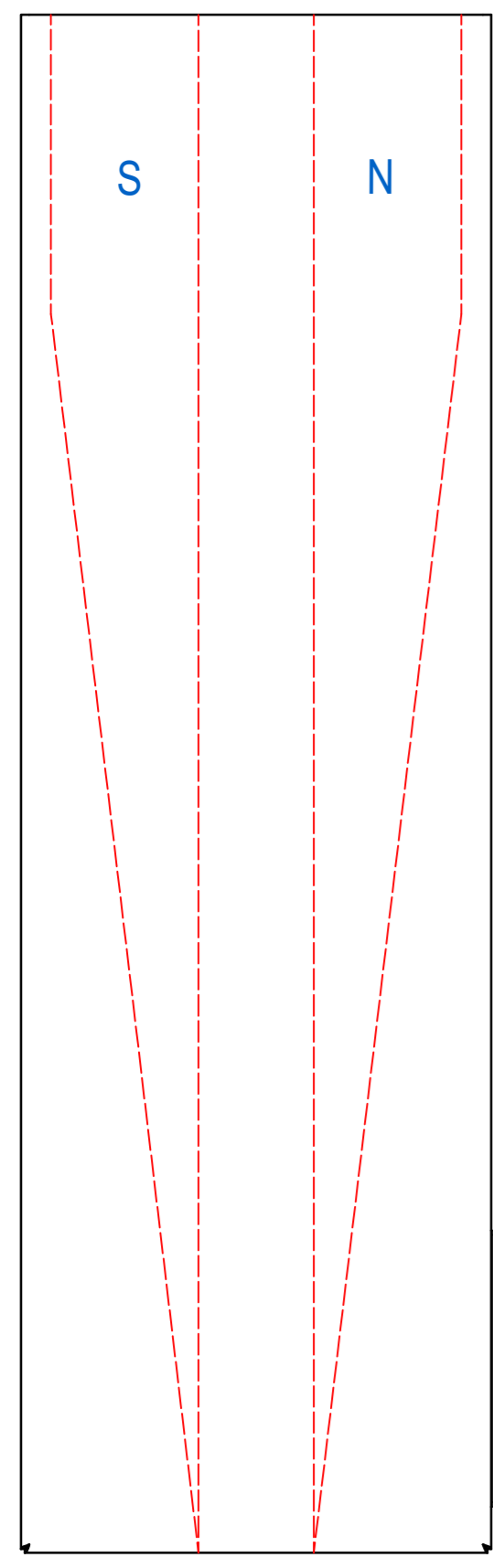

ITEM	QTY	PART NUMBER	DESCRIPTION	Dimensions
2	1	E0156615	HRA-TYPE PLATE STICKER	
1	1	E0154788	HRA-WELD ASSY	
RAW MAT.	Quantity	Material Number	Material Description	Length (mm) Width (mm)
	1			
Sheet: A2		Extra info: INCREASING FIELD		General tolerance: ISO 2768- mK
Drawn: PB		Weight (kg): 2,5		Drawn according: ISO268; ISO1101; ISO2553
Date: 19-6-2014		Source: MC-C		Status: Standard
Spare part: False		Quick search: TBBC03		Customer reference number:
Description: HRA-F-102x24-BC-0335-B-B		© All rights reserved. Reproduction is not permitted without written permission of GOUDSMIT Magnetic Systems BV		Document number: TBBC033503 Doc.Rev: B
		Part number: TBBC033503		Rev: B