

REV	DATE	BY	DESCRIPTION
-	7-7-2014	BS	NEW VAULT, NEW REVISION. NOTHING CHANGED. OLD REV WAS B
A	18-1-2023	DK	STICKER AND SOURCE CODE ADDED, FILES DEMOTED

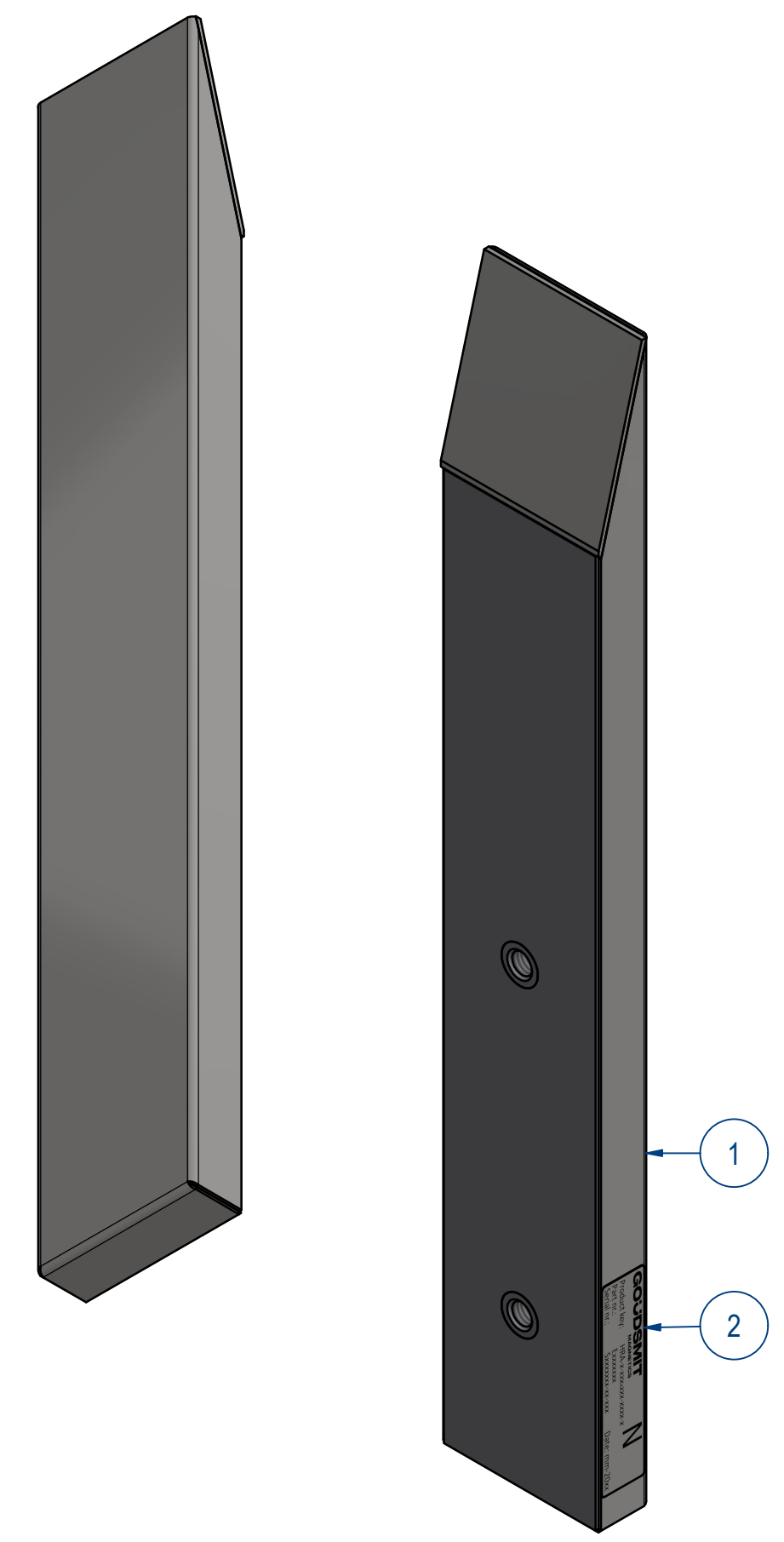
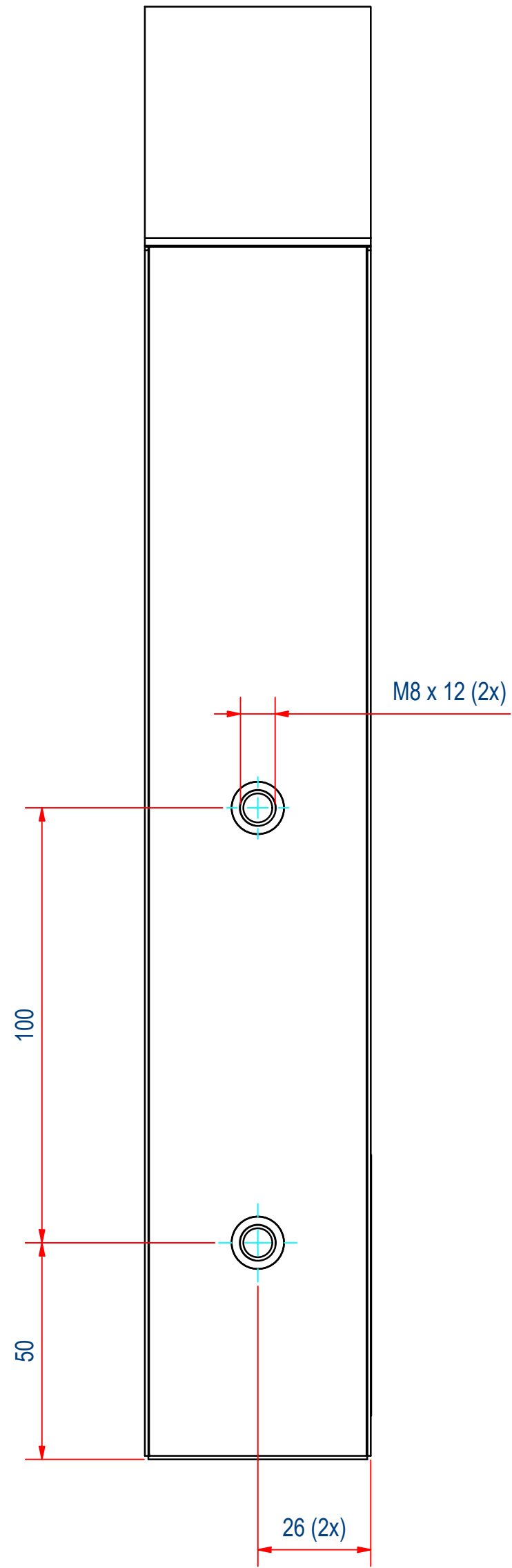
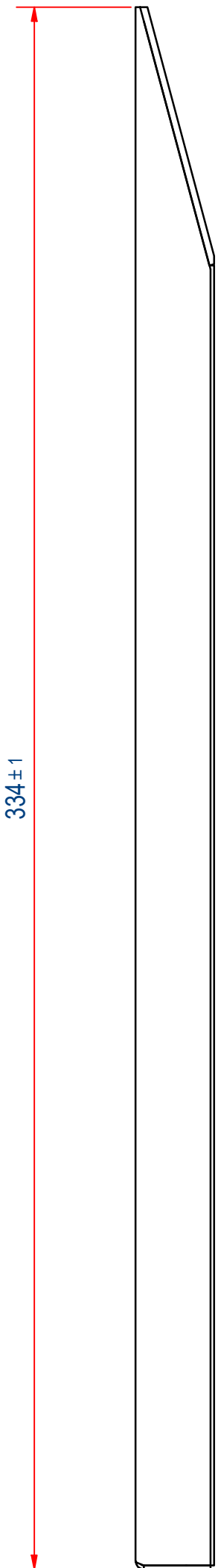
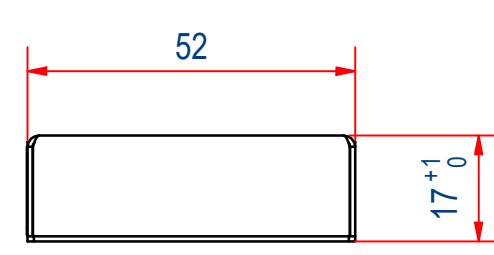
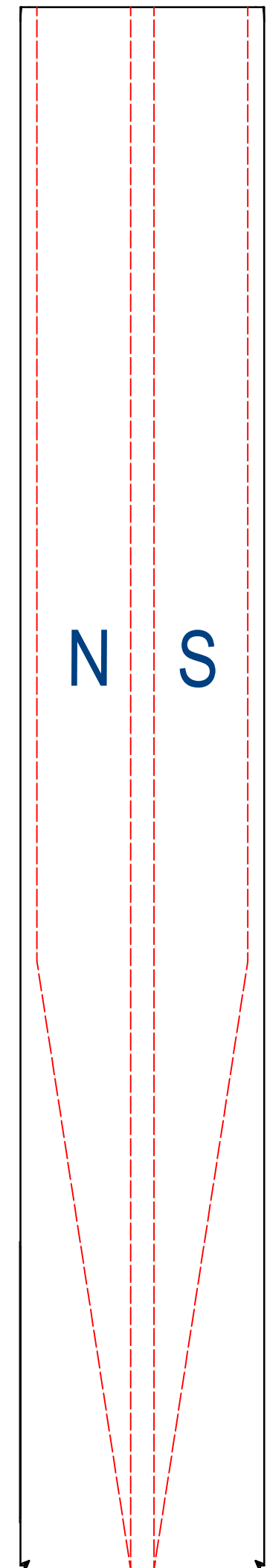

ITEM	QTY	PART NUMBER	DESCRIPTION	Dimensions
2	1	E0156615	HRA-TYPE PLATE STICKER	
1	1	E0157327	HRA-WELD ASSY	

RAW MAT.	Quantity	Material Number	Material Description	Length (mm)	Width (mm)
	1				

Sheet:	A2	Extra info:	WEAKENING SIDE	General tolerance:	ISO 2768 - mK
Drawn:	BS	Weight (kg):	1,3	Drawn according:	ISO268; ISO1101; ISO2553
Date:	7-7-2014	Status:	Standard	Customer reference number:	
Spare part:	False	Source:	MC-C	Document number:	TBBD033501
Quick search:	TBBC01	Description:	HRA-F-052x17-BD-0335-B-B	Doc.Rev:	A
				Part number:	TBBD033501
				Rev:	A