

REV	DATE	BY	DESCRIPTION
-	10-6-2014	BS	NEW VAULT, NOTHING CHANGED, IS EQUAL TO OLD REVISION B
A	9-12-2022	LH	DEMOTED WELD ASSY ADDED STICKER

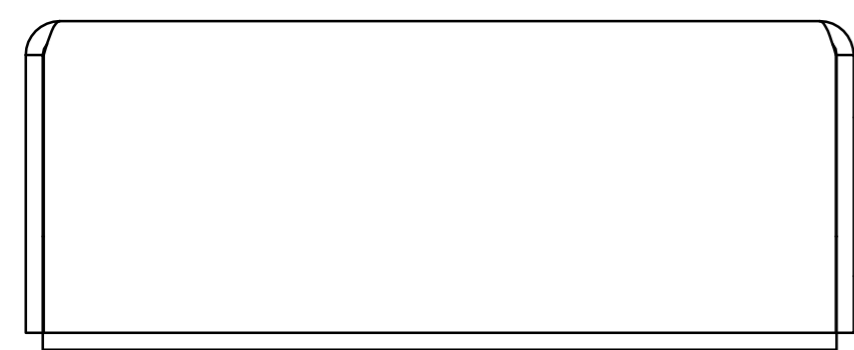

ITEM	QTY	PART NUMBER	DESCRIPTION	Dimensions
2	1	E0156369	HSS-TYPE PLATE STICKER	
1	1	E0156508	HSS-WELD ASSY	
RAW MAT.	1			
Quantity		Material Number	Material Description	Length (mm) Width (mm)
Sheet:	A2	Extra info:	SHEET SEPARATOR	
Drawn:	BS	Weight (kg):	0,88	
Date:	10-6-2014	General tolerance:	ISO 2768- mK	
Spare part:	False	Source:	MC-C	
Quick search:	TBSP00	Drawn according:	ISO268; ISO1101; ISO2553	
Description:	HSS-F-BA-073x029-0075-B		Status:	Released
			Customer reference number:	
			Document number:	TBSP000075
			Doc.Rev:	A
			Part number:	TBSP000075
			Rev:	A

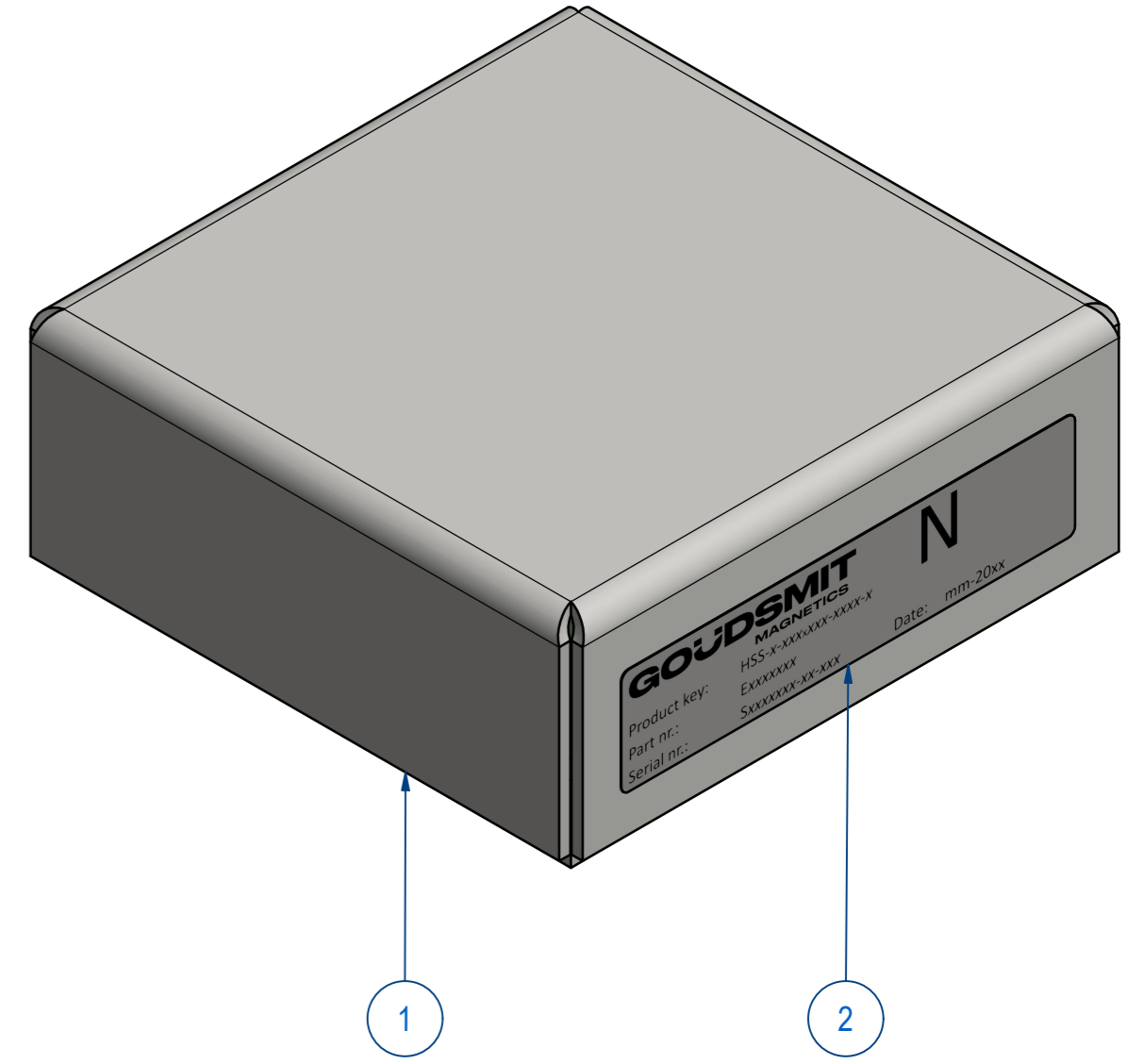
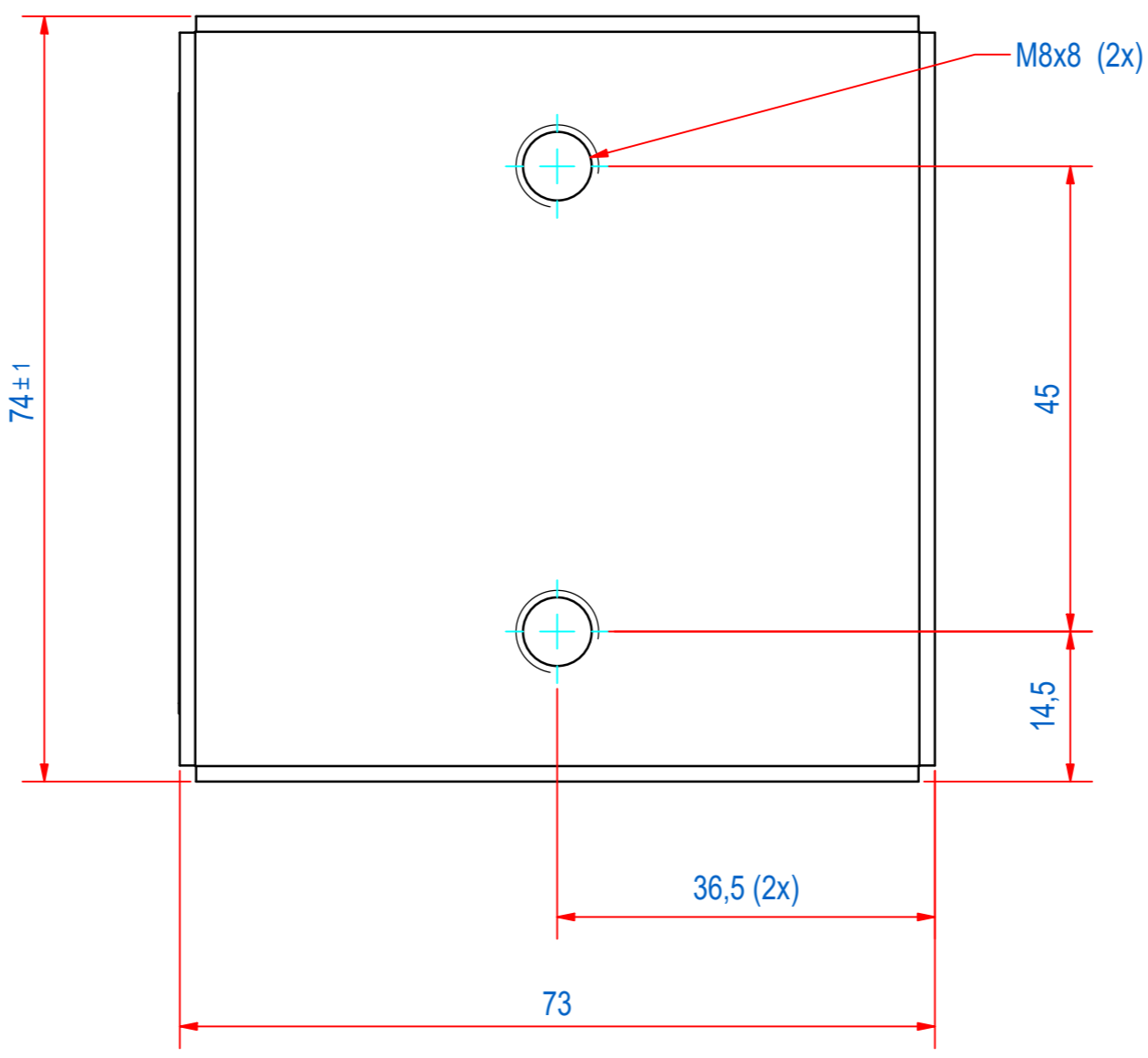
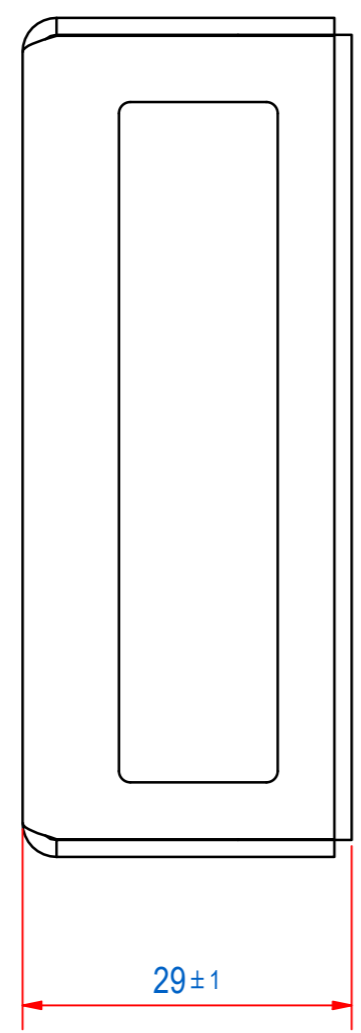
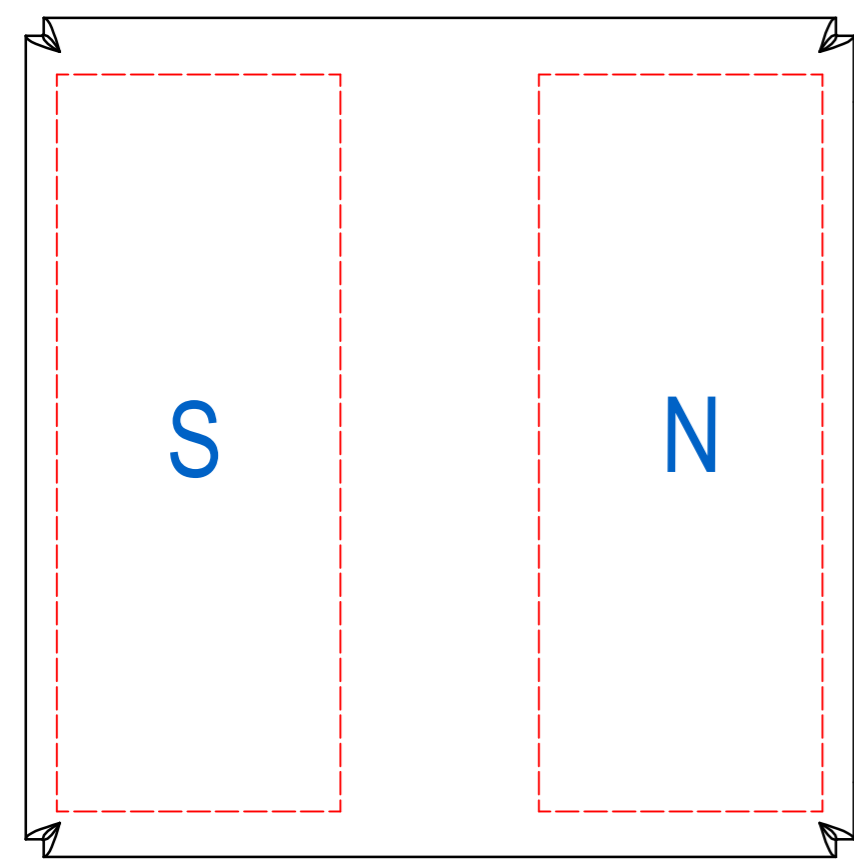

© All rights reserved. Reproduction is not permitted without written permission of GOUDSMIT Magnetic Systems BV