

REV	DATE	BY	DESCRIPTION
-	10-6-2014	BS	NEW VAULT, NOTHING CHANGED, IS EQUAL TO OLD REVISION A
A	9-12-2022	LH	WELD ASSY DEMOTED, STICKER ADDED

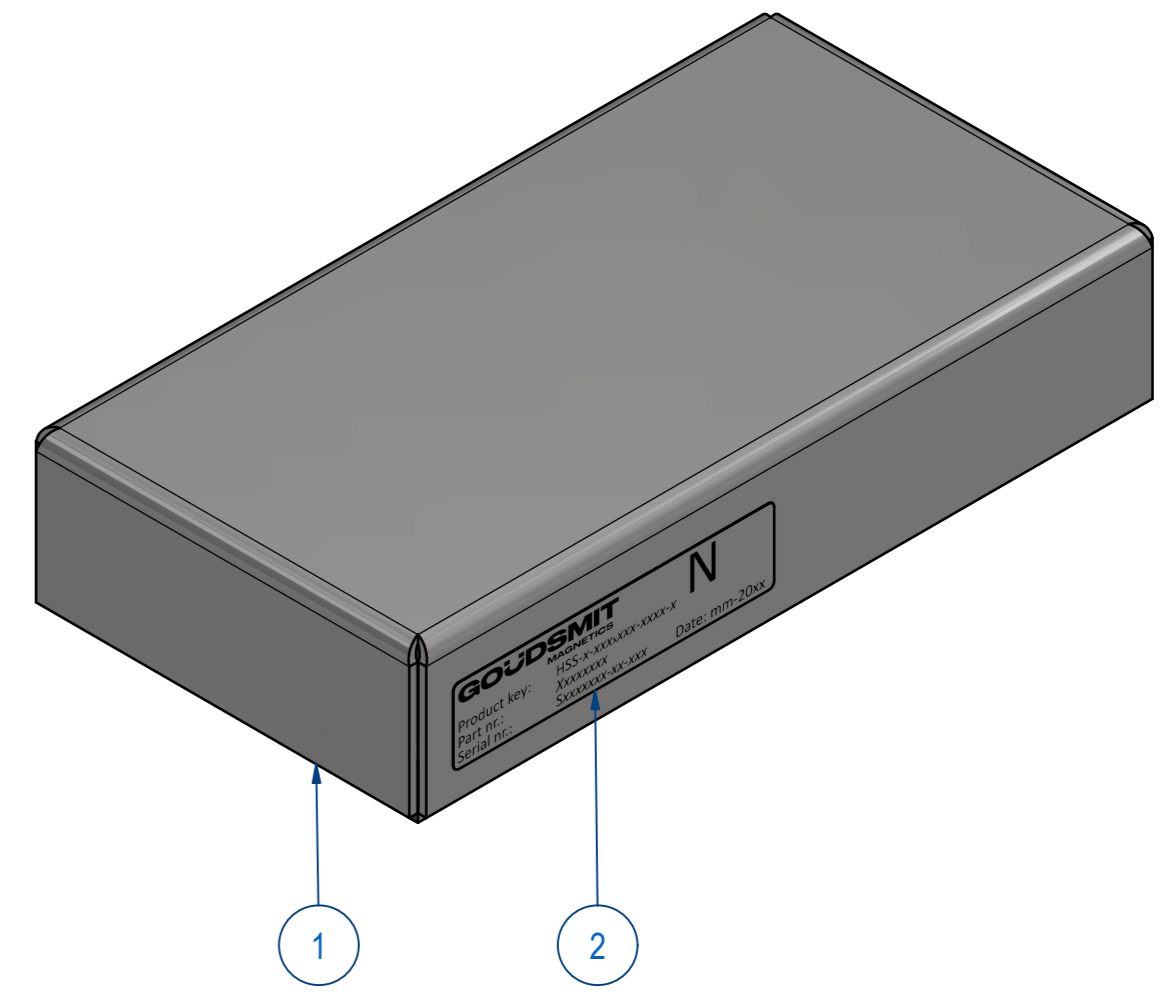

ITEM	QTY	PART NUMBER	DESCRIPTION	Dimensions
2	1	E0156369	HSS-TYPE PLATE STICKER	
1	1	E0156510	HSS-WELD ASSY	
RAW MAT.	1			
Quantity		Material Number	Material Description	Length (mm) Width (mm)
Sheet:	A2	Extra info:	SHEET SEPARATOR	
Drawn:	PB	Weight (kg):	1,7	
Date:	10-6-2014	General tolerance:	ISO 2768- mK	
Spare part:	False	Source:	MC-C	
Quick search:	TBSP00	Drawn according:	ISO268; ISO1101; ISO2553	
Description:	HSS-F-BA-073x029-0140-B		Status:	Standard
		Customer reference number:		
		Document number:	TBSP000140	Doc.Rev: A
		Part number:	TBSP000140	Rev: A

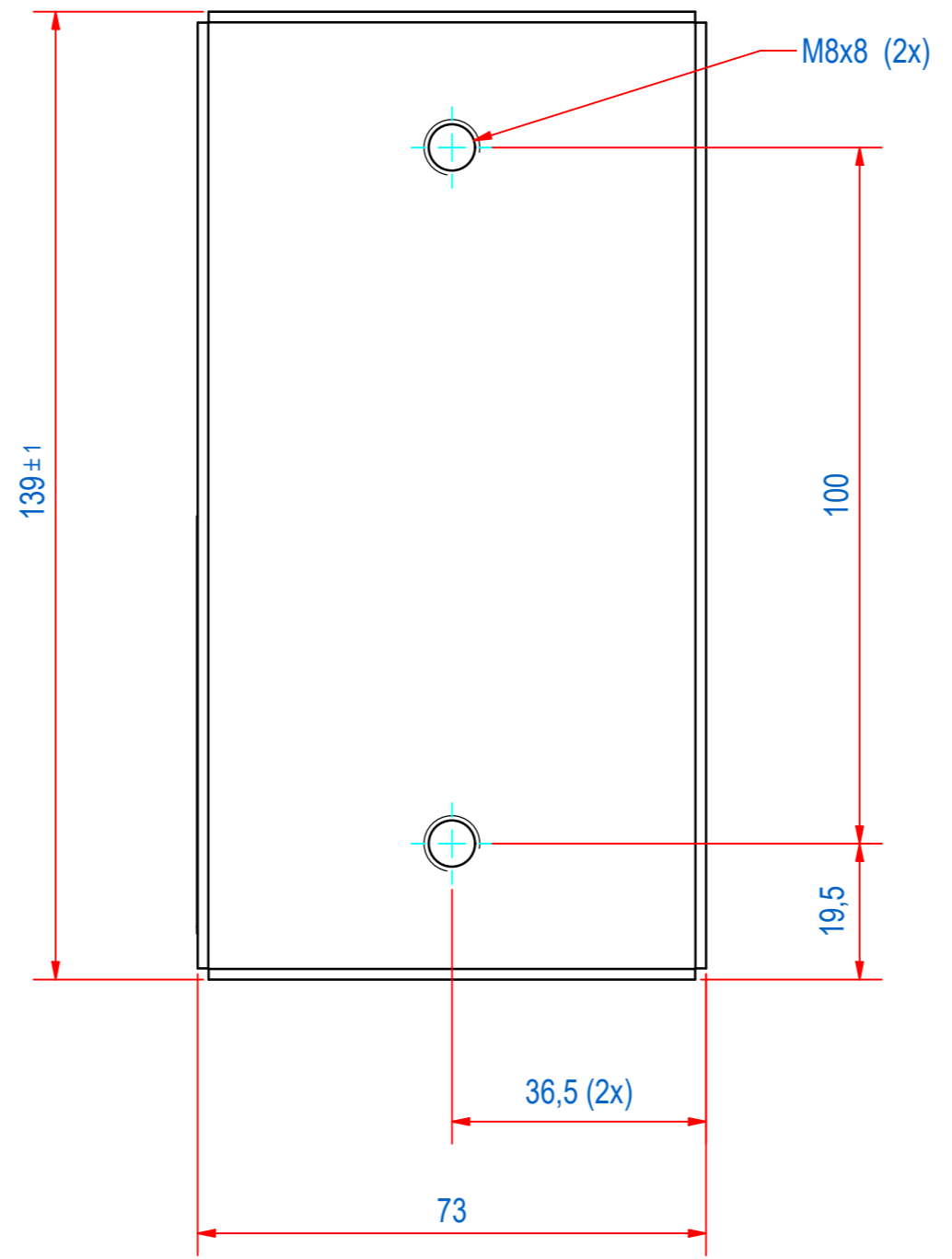
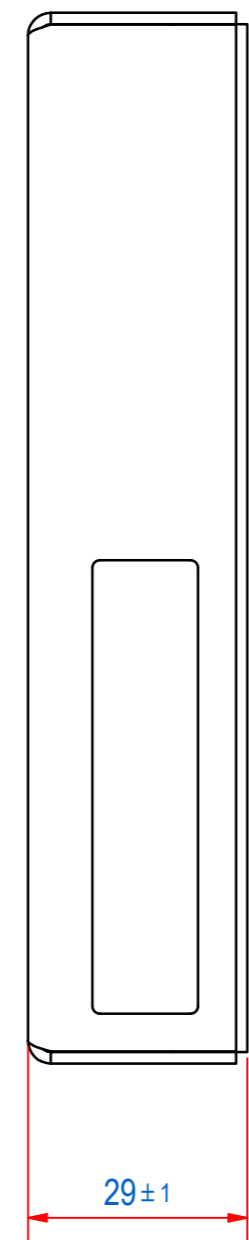
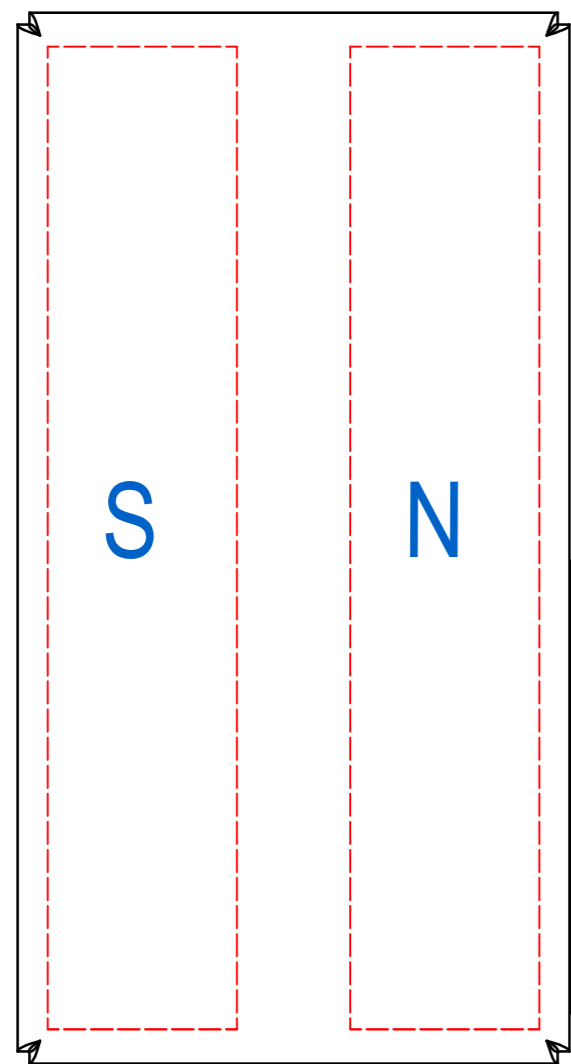

© All rights reserved. Reproduction is not permitted without written permission of GOUDSMIT Magnetic Systems BV