

REV	DATE	BY	DESCRIPTION
-	5-6-2014	BS	NOTHING CHANGED, OLD REVISION A
A	17-10-2019	PB	IN OLD ACAD REV A DIM 140 WAS 150
B	11-4-2023	LH	WELD ASSY DEMOTED, STICKER ADDED

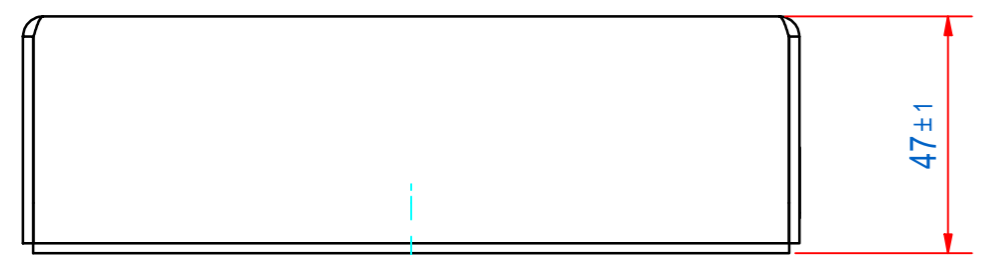

ITEM	QTY	PART NUMBER	DESCRIPTION	Dimensions
2	1	E0156369	HSS-TYPE PLATE STICKER	
1	1	E0156517	HSS-WELD ASSY	
RAW MAT.	Quantity	Material Number	Material Description	Length (mm) Width (mm)
	1			
Sheet: A2		Extra info: SHEET SEPARATOR		General tolerance: ISO 2768 - mK
Drawn: BS	Weight (kg): 7,6			Drawn according: ISO268; ISO1101; ISO2553
Date: 5-6-2014			Status: Standard	
Spare part: False	Source: MC-C			Customer reference number:
Quick search: TBSP03			Document number: TBSP030210	Doc.Rev: B
Description: HSS-F-BA-154x047-0210-B			Part number: TBSP030210	Rev: B

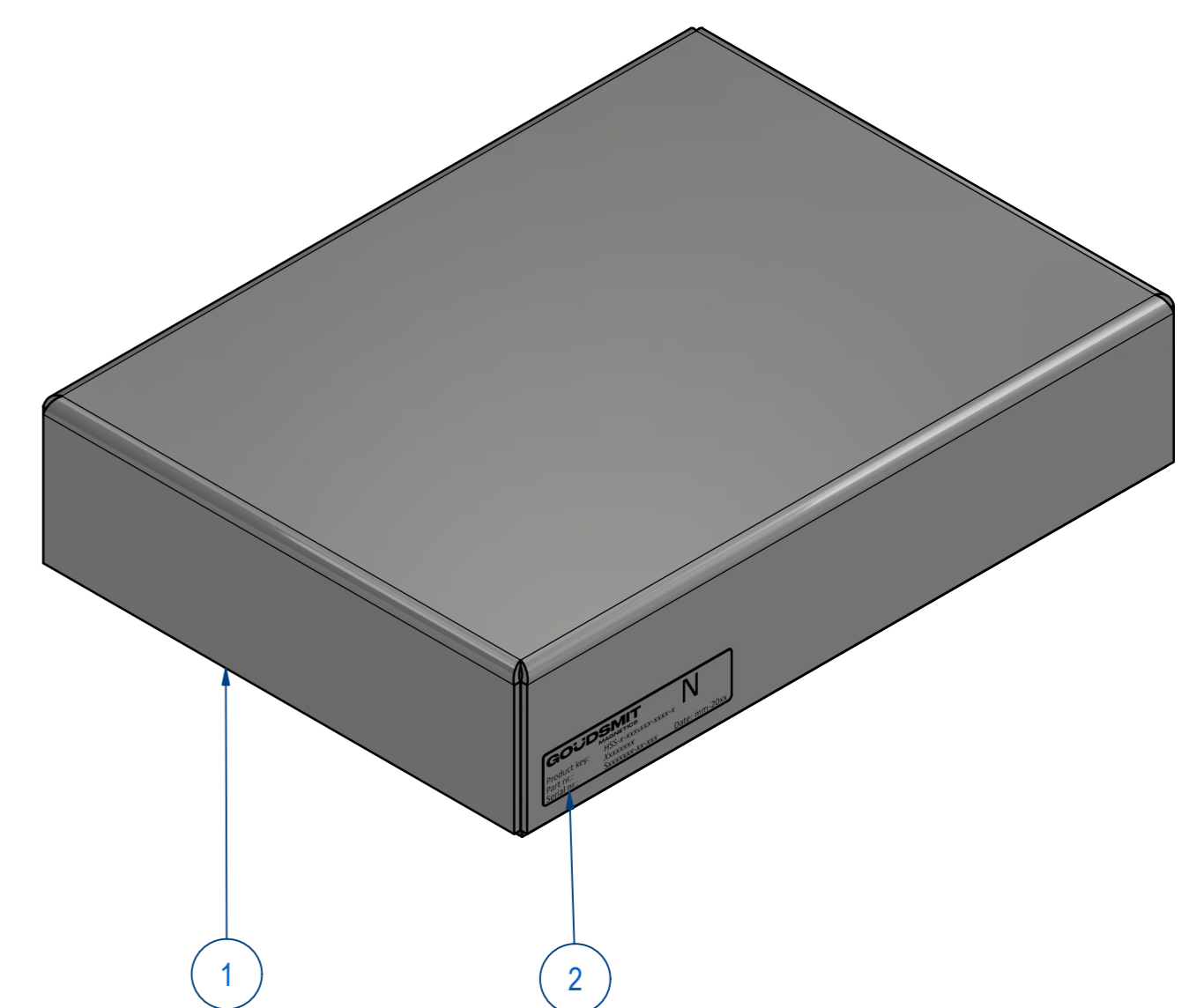
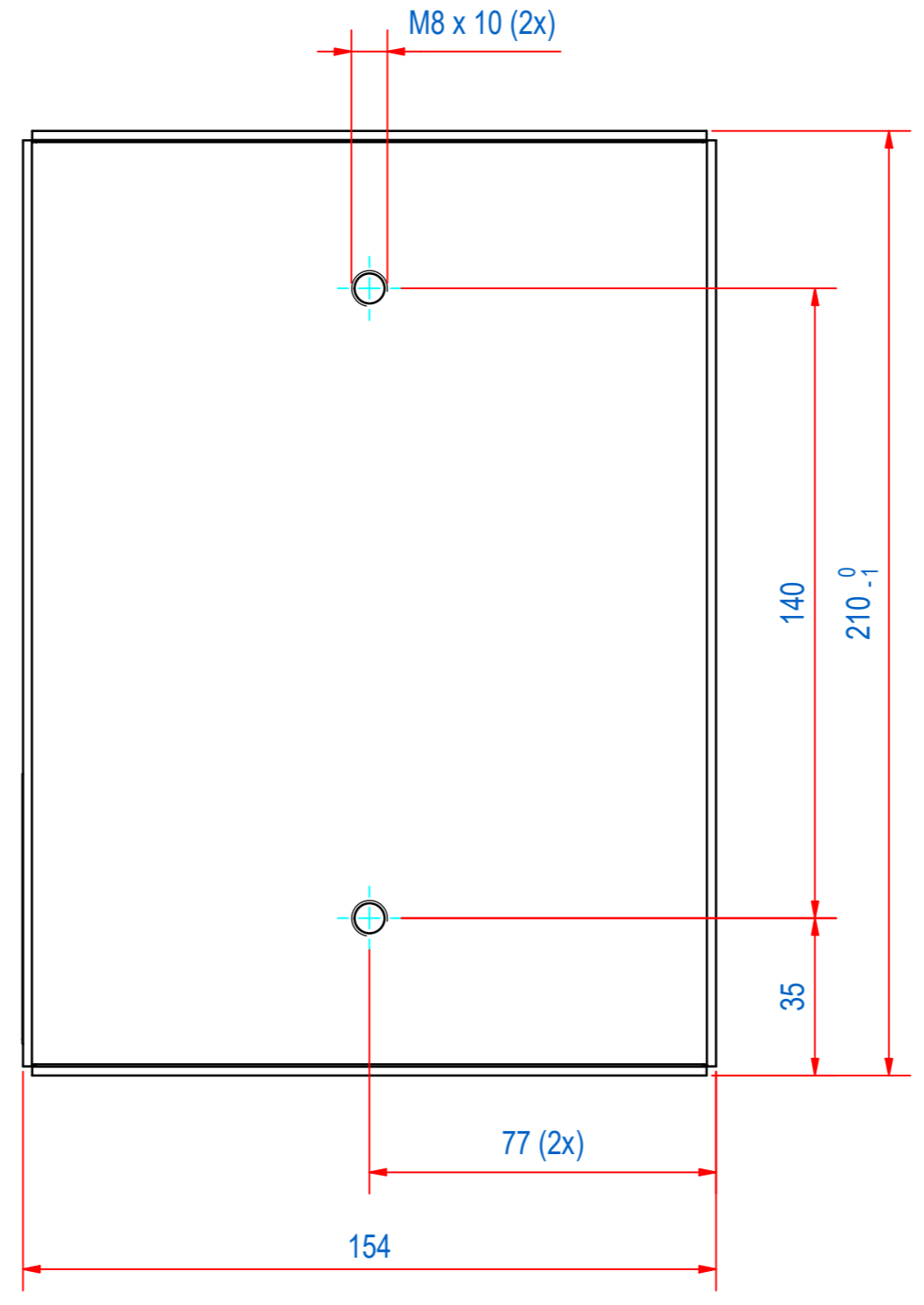
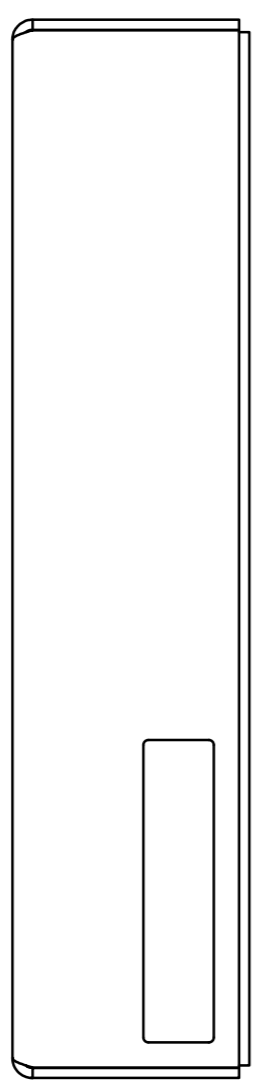
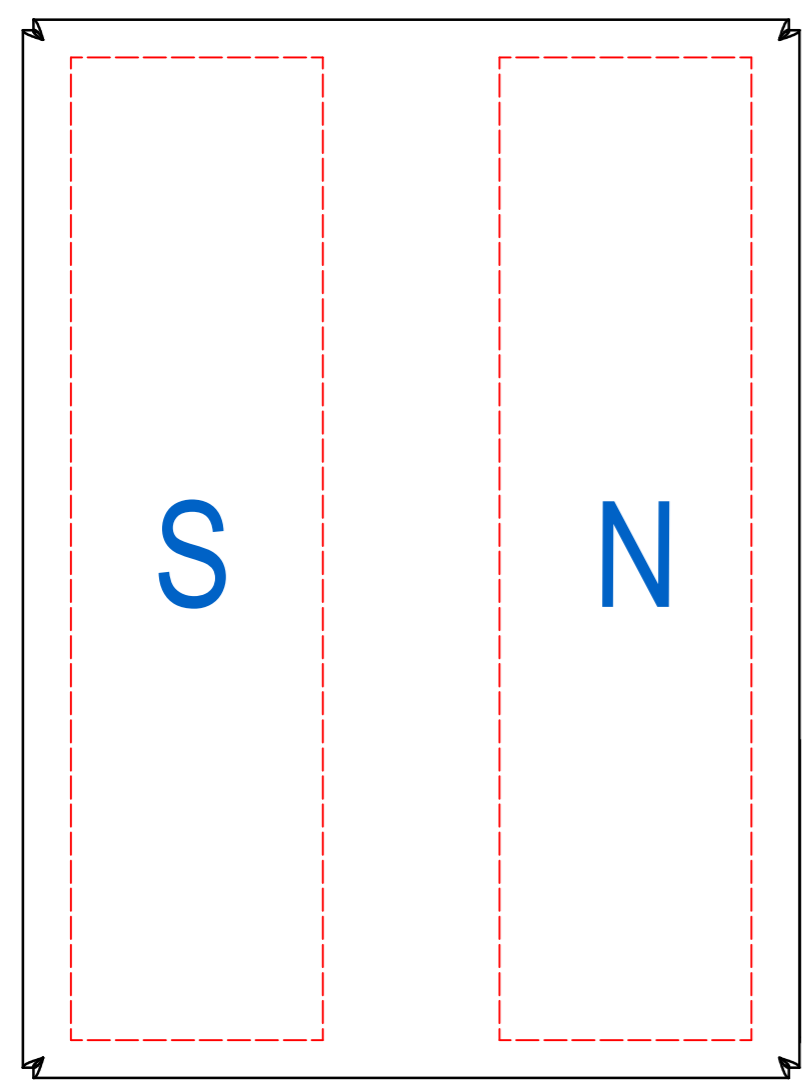

© All rights reserved. Reproduction is not permitted without written permission of GOUDSMIT Magnetic Systems BV