

REV	DATE	BY	DESCRIPTION
-	12-4-2019	PB	REFERENCE MODEL: TCMO100200
A	9-3-2023	DK	SOURCE CODE ADDED

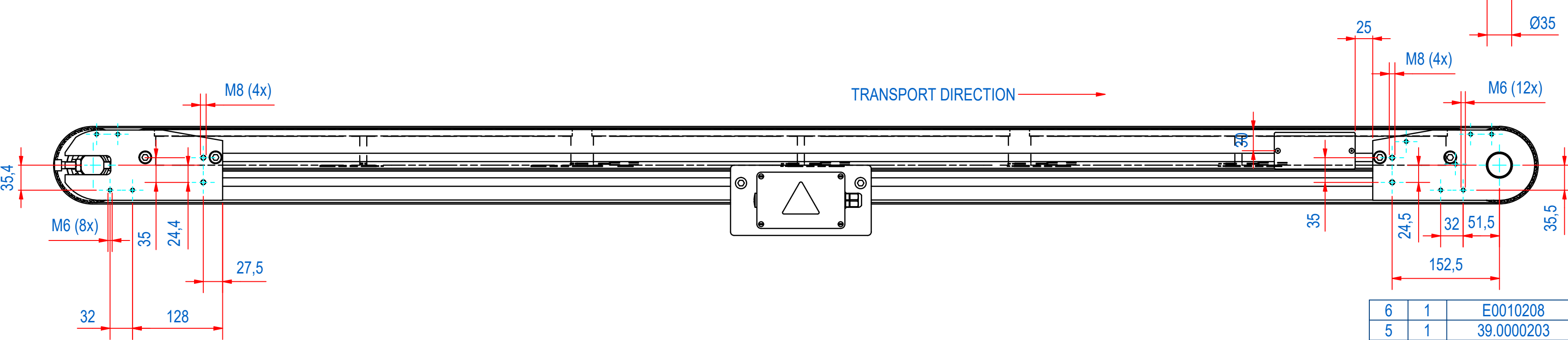
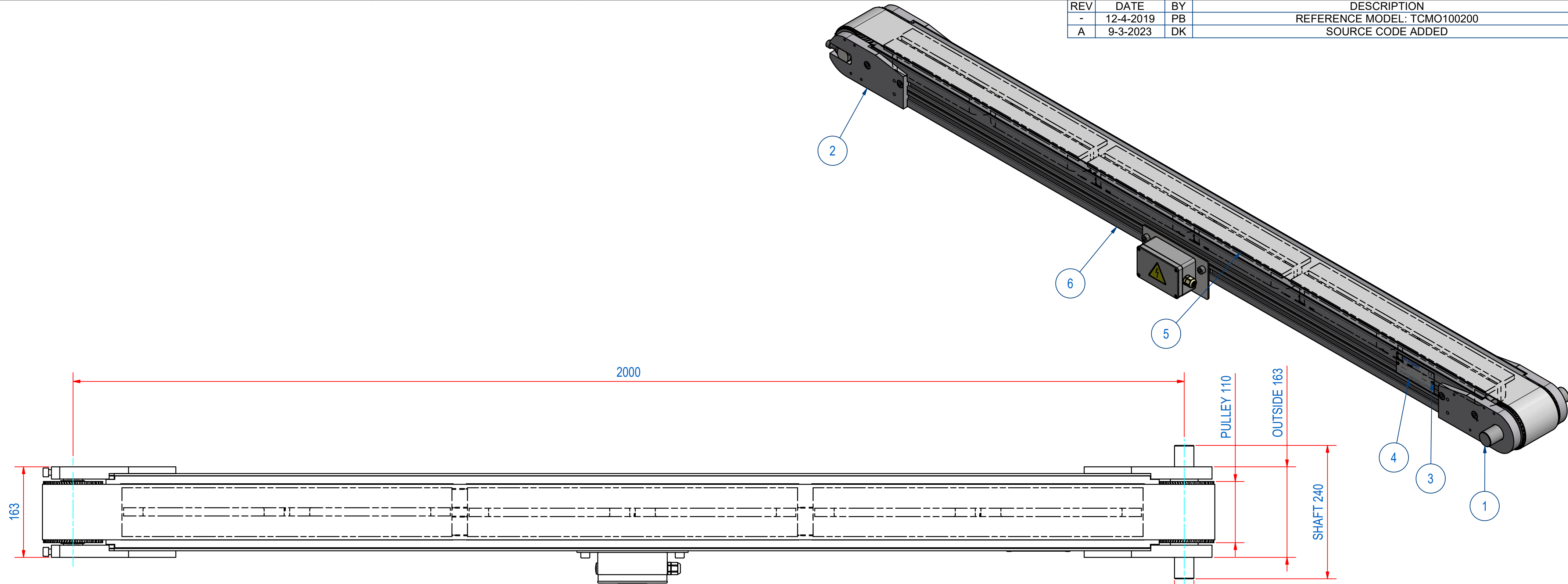

ITEM	QTY	PART NUMBER	DESCRIPTION	Dimensions
6	1	E0010208	HCT-EXTRUSION	
5	1	39.0000203	TIMINGBELT 100BATK10-PAZ/4340	
4	1	E0093917	DATA PLATE SMALL	
3	2	58.0600005	POP RIVET ALU Ø4x8	
2	1	A190039	HCT-RETURN PULLEY ASSY	
1	1	E0038802	HCT-SPARE-DRIVE PULLEY ASSY	

RAW MAT.	Quantity: 1	Material Number:	Material Description:	Length (mm):	Width (mm):
Sheet:	A2	Extra info:	TIMING BELT CONVEYOR	General tolerance:	ISO 2768 - mK
Drawn:	PB	Weight (kg):	59	Drawn according:	ISO268; ISO1101; ISO2553
Date:	8-7-2019	Status:	Standard	Customer reference number:	
Spare part:	False	Source:	MC-C	Document number:	TCMO100222
Quick search:	TCMO100			Doc.Rev:	A
Description:	HCT-E-B100-2000-C-R-N			Part number:	TCMO100222
				Rev:	A