

REV	DATE	BY	DESCRIPTION
A	7-12-2022	DK	SOURCE CODE ADDED, TYPE PLATE ADDED TO BOM
B	12-12-2022	DK	DIMENSIONING CHANGED
C	14-12-2022	DK	TOLERANCE OF LENGTH CHANGED

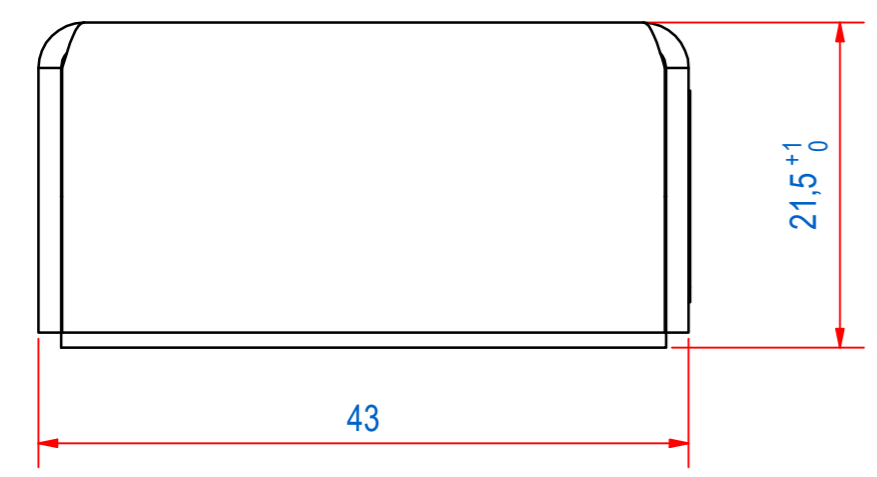

ITEM	QTY	PART NUMBER	DESCRIPTION	Dimensions
2	1	E0156369	HSS-TYPE PLATE STICKER	
1	1	E0156310	HSS-WELD AND MOULD ASSY	
RAW MAT.	Quantity	Material Number	Material Description	Length (mm) Width (mm)
Sheet: A2		Extra info: SHEET SEPARATOR		General tolerance: ISO 2768 - mK
Drawn: PB		Weight (kg): 1,4		Drawn according: ISO268; ISO1101; ISO2553
Date: 3-2-2014		Source: MC-C		Status: Standard
Spare part: False		Quick search: TGSP00		Customer reference number:
Description: HSS-N-BA-043x022-0075-B		Document number: TGSP000075		Doc.Rev: C
		Part number: TGSP000075		Rev: C

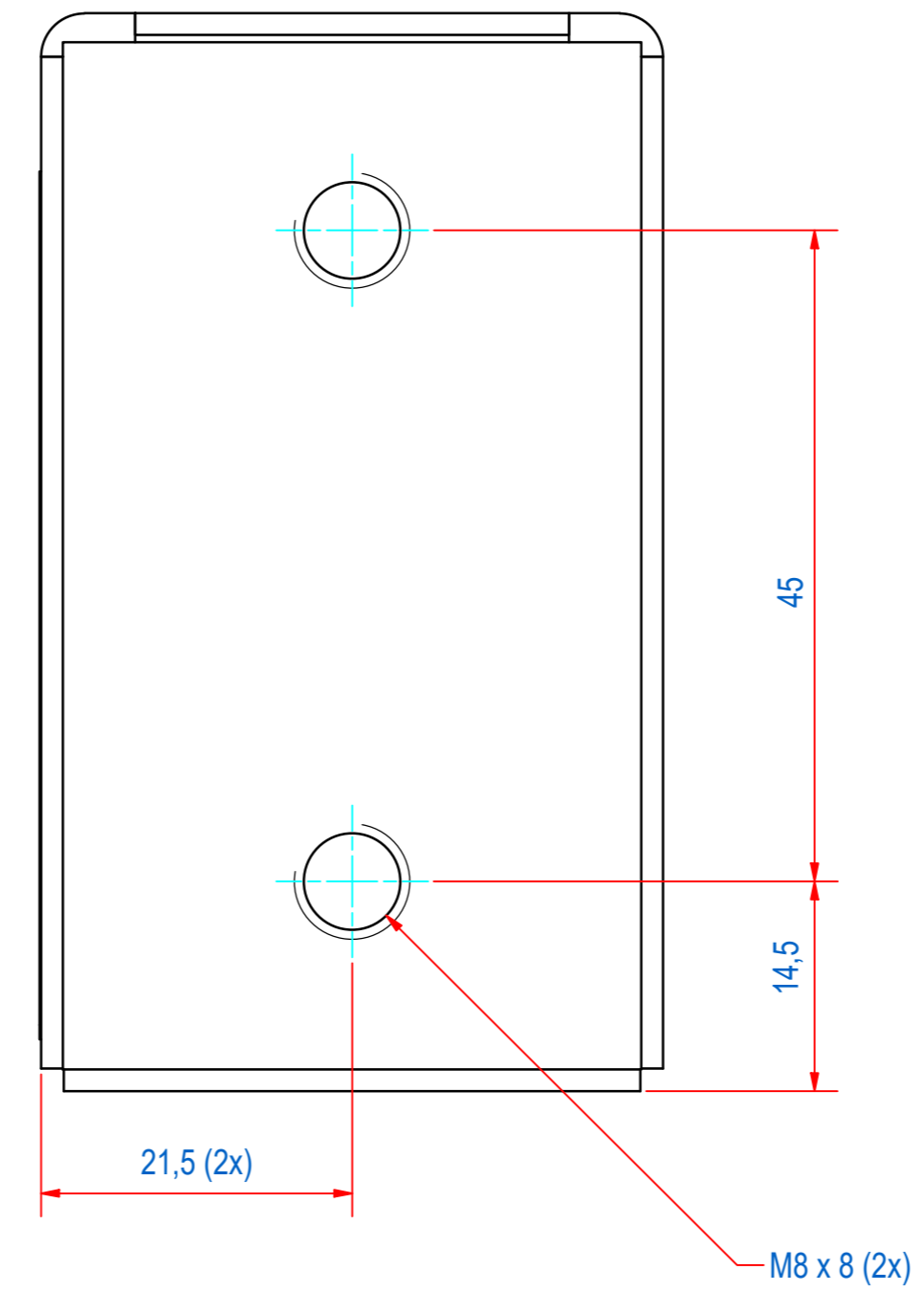
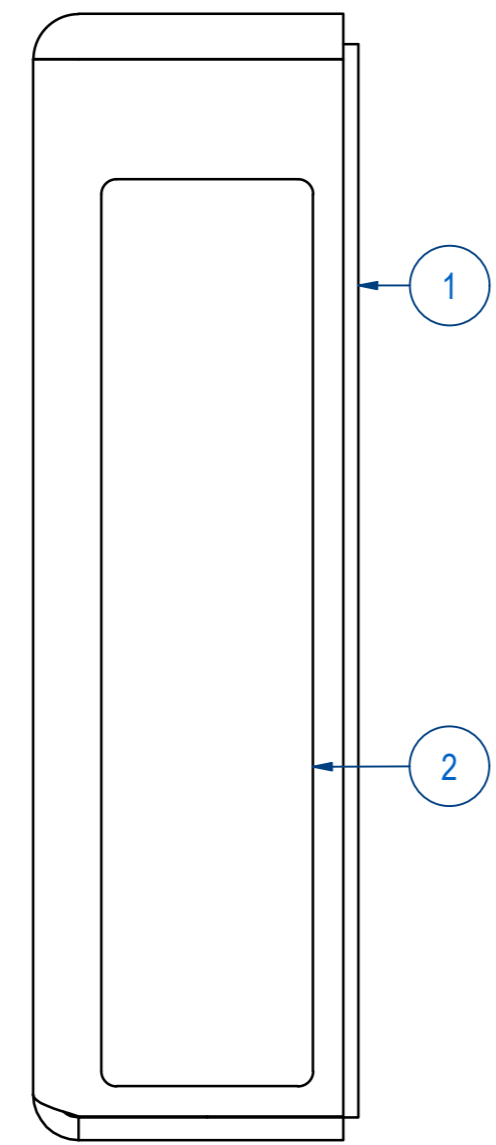
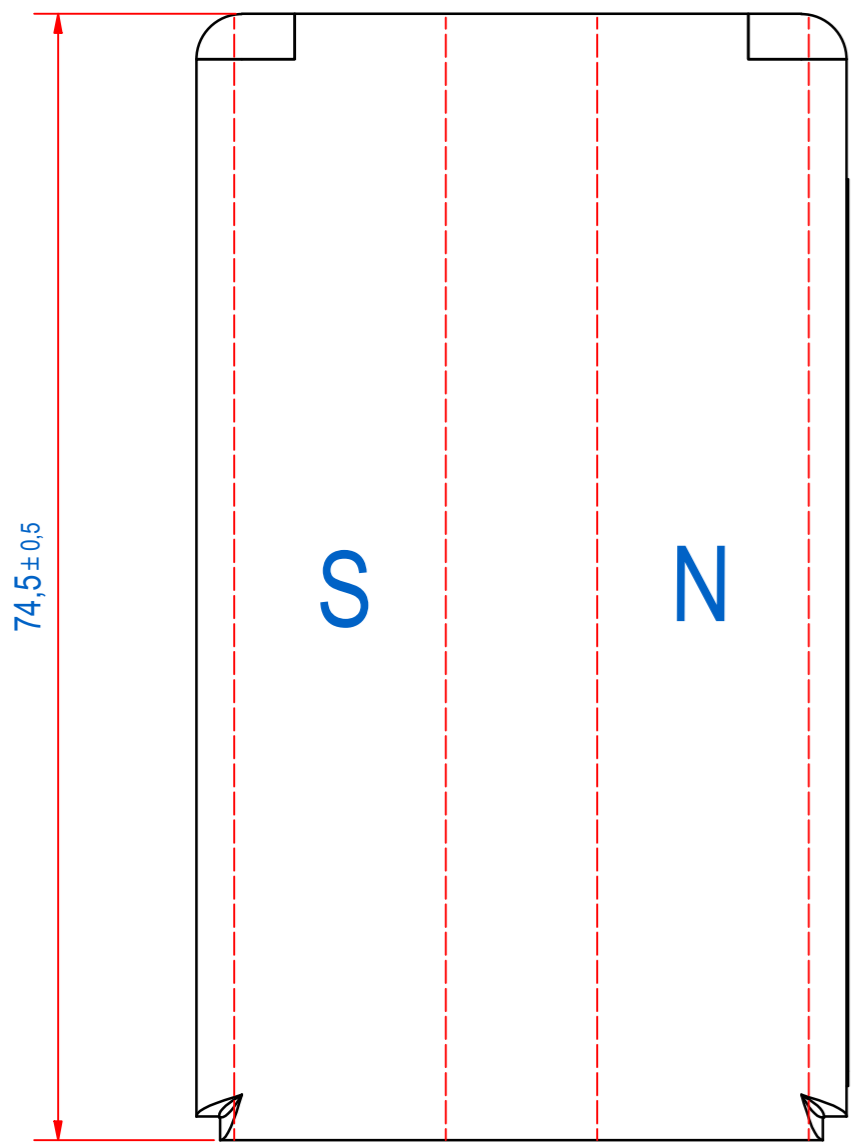
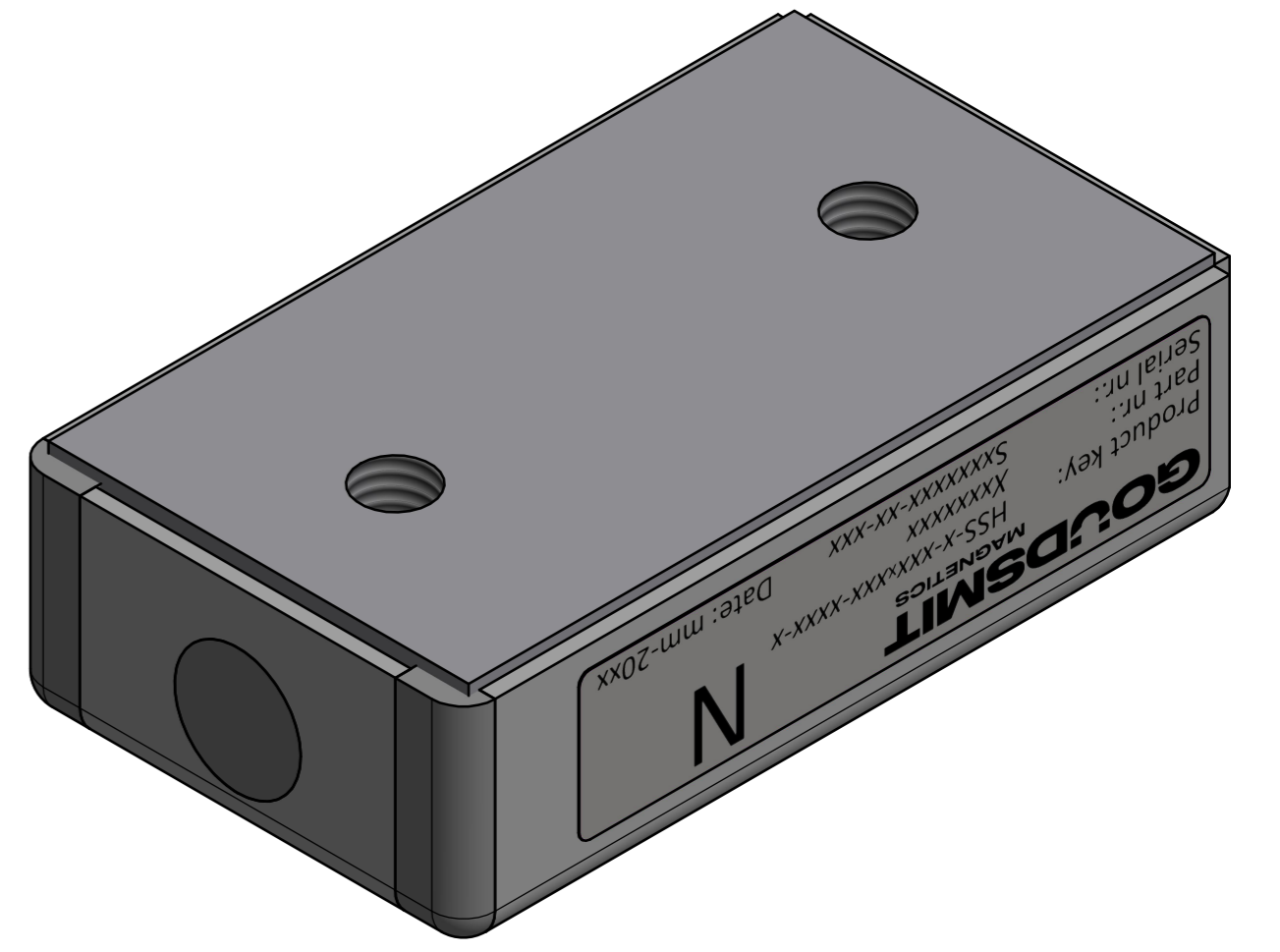

© All rights reserved. Reproduction is not permitted without written permission of GOUDSMIT Magnetic Systems BV