

REV	DATE	BY	DESCRIPTION
-	12-9-2013	BS	NEW VAULT, NEW REVISION. ALL ITEMS WERE IN THIS DRAWING.
A	3-8-2022	PB	WELD ASSY ADDED
B	14-12-2022	DK	SOURCE CODE ADDED, TYPE PLATE ADDED

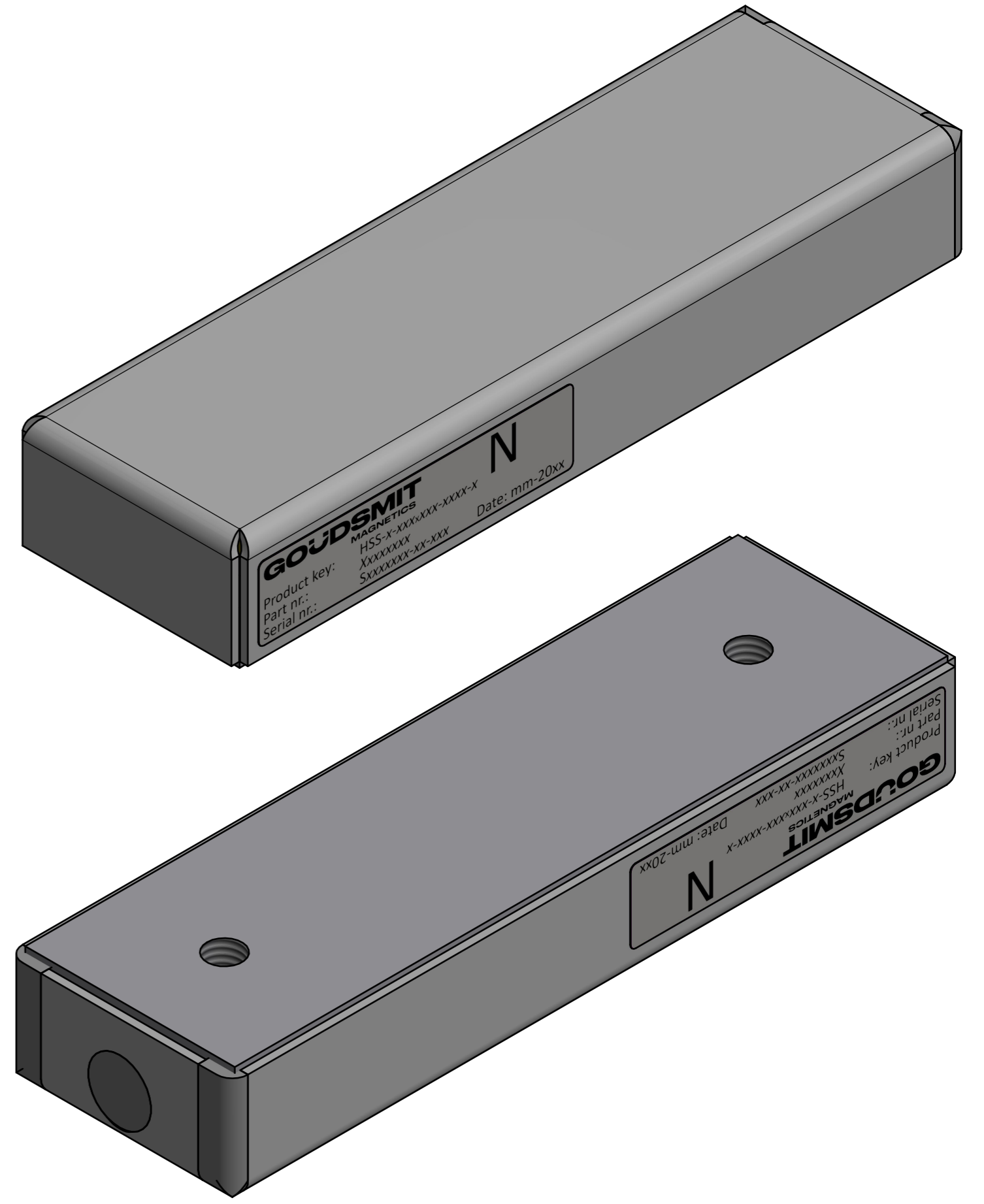
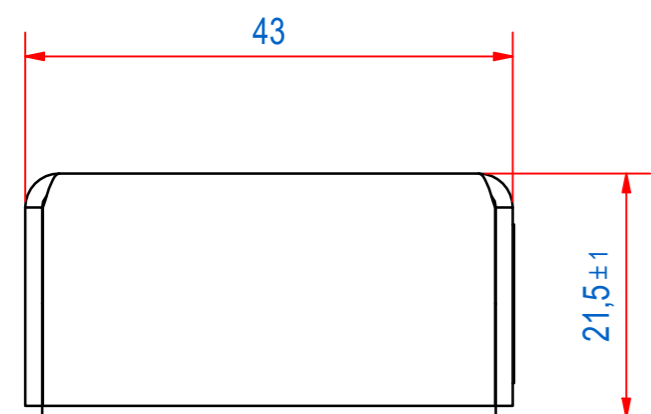
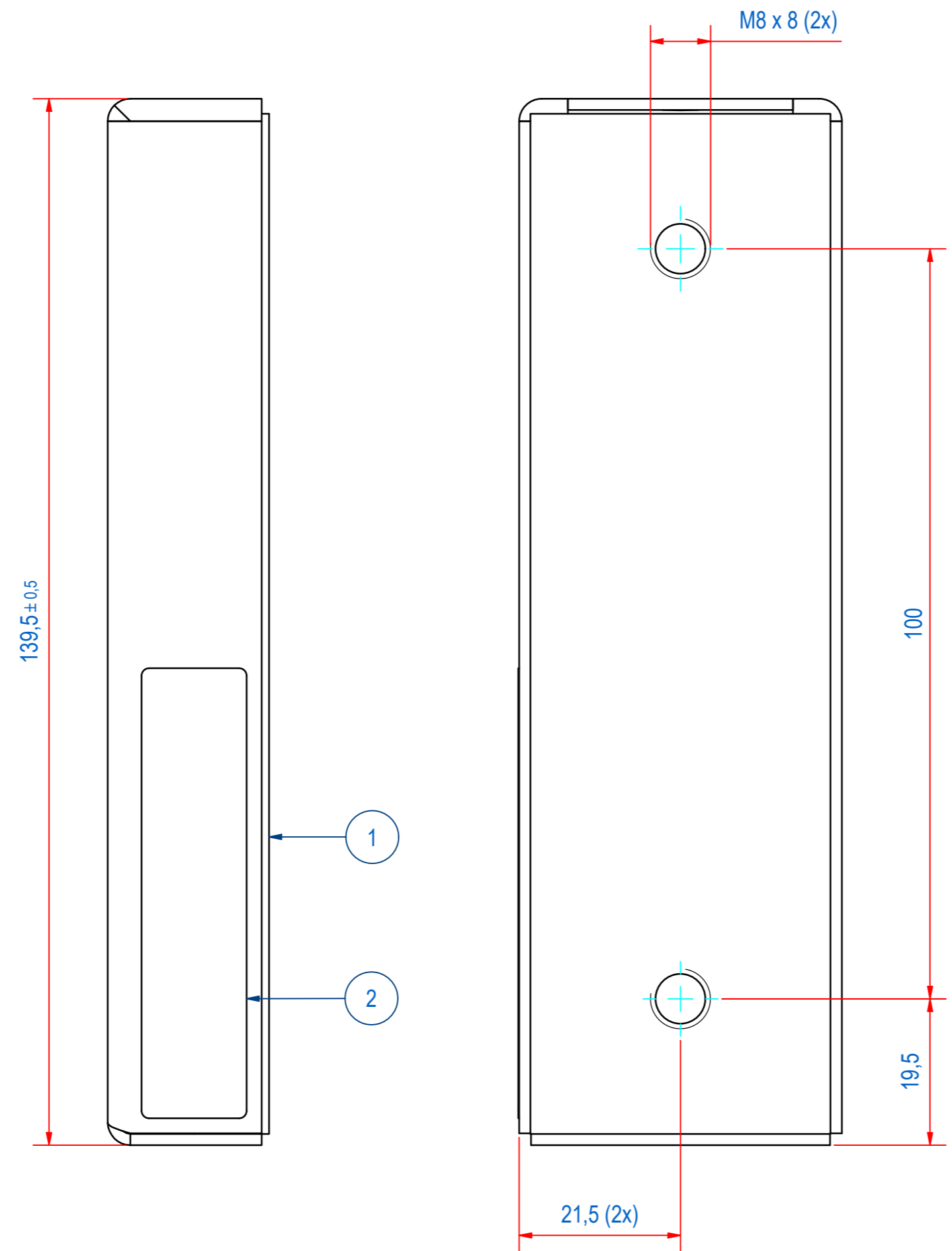
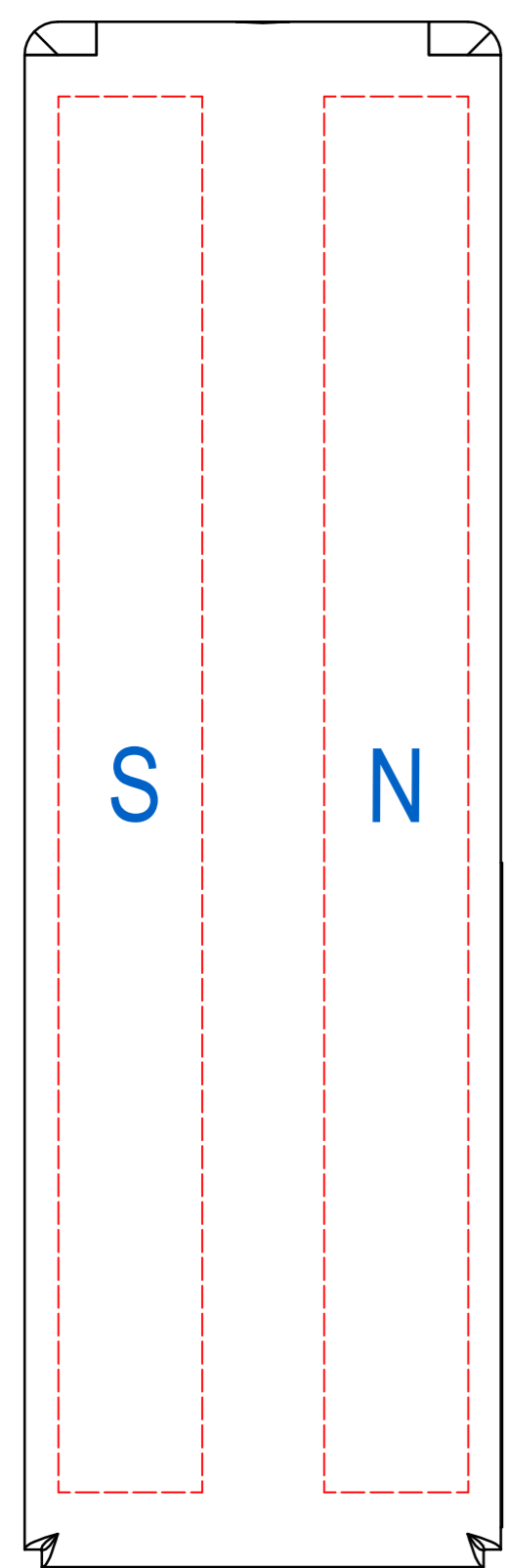

ITEM	QTY	PART NUMBER	DESCRIPTION	Dimensions
2	1	E0156369	HSS-TYPE PLATE STICKER	
1	1	E0154085	HSS-WELD AND MOULD ASSY	
RAW MAT.	1			Length (mm) Width (mm)
Quantity		Material Number	Material Description	General tolerance:
Sheet: A2		Extra info: SHEET SEPARATOR		ISO 2768 - mK
Drawn: BS		Weight (kg): 1,8		Drawn according: ISO268; ISO1101; ISO2553
Date: 12-9-2013		Source: MC-C		Status: Standard
Spare part: False		Quick search: TGSP00		Customer reference number:
Description: HSS-N-BA-043x022-0140-B		© All rights reserved. Reproduction is not permitted without written permission of GOUDSMIT Magnetic Systems BV		Document number: TGSP000140 Doc.Rev: B
		Part number: TGSP000140		Rev: B