

DOC.NR.	REV	DATE	BY	DESCRIPTION
TGSP010075	B	13-12-2022	DK	STICKER TYPE PLATE EXCHANGED WITH ETCH TYPE PLATE
TGSP010075	C	27-2-2024	PB	UPDATE AFTER COVER REVISION
TGSP010075	D	21-5-2024	PB	ADDED 1000.20027 AND 1000.20072

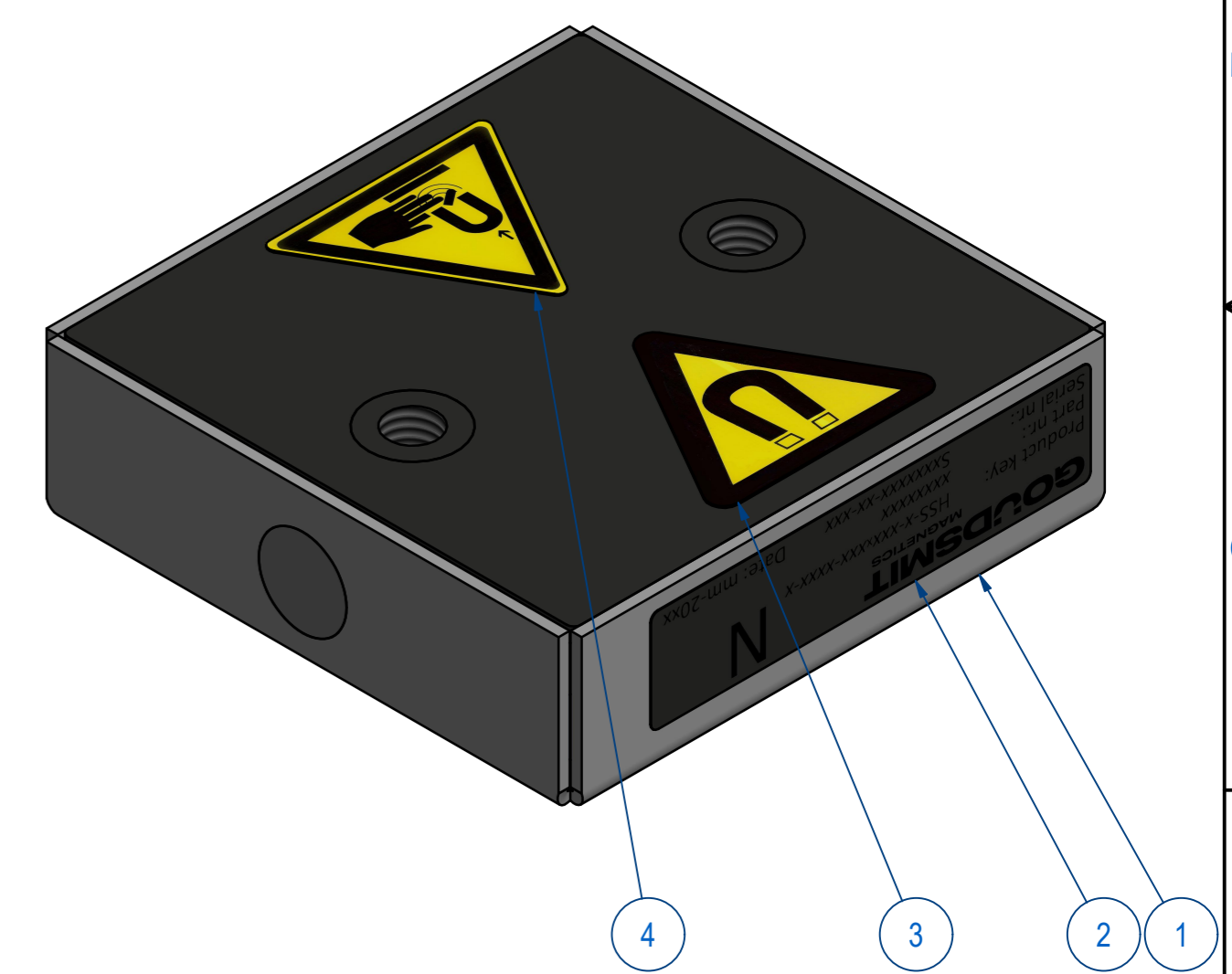
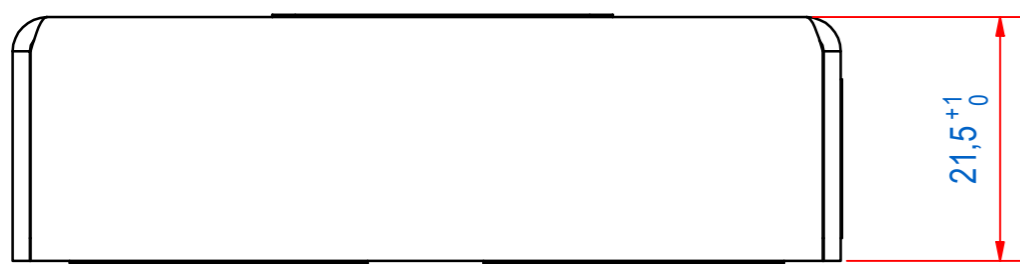
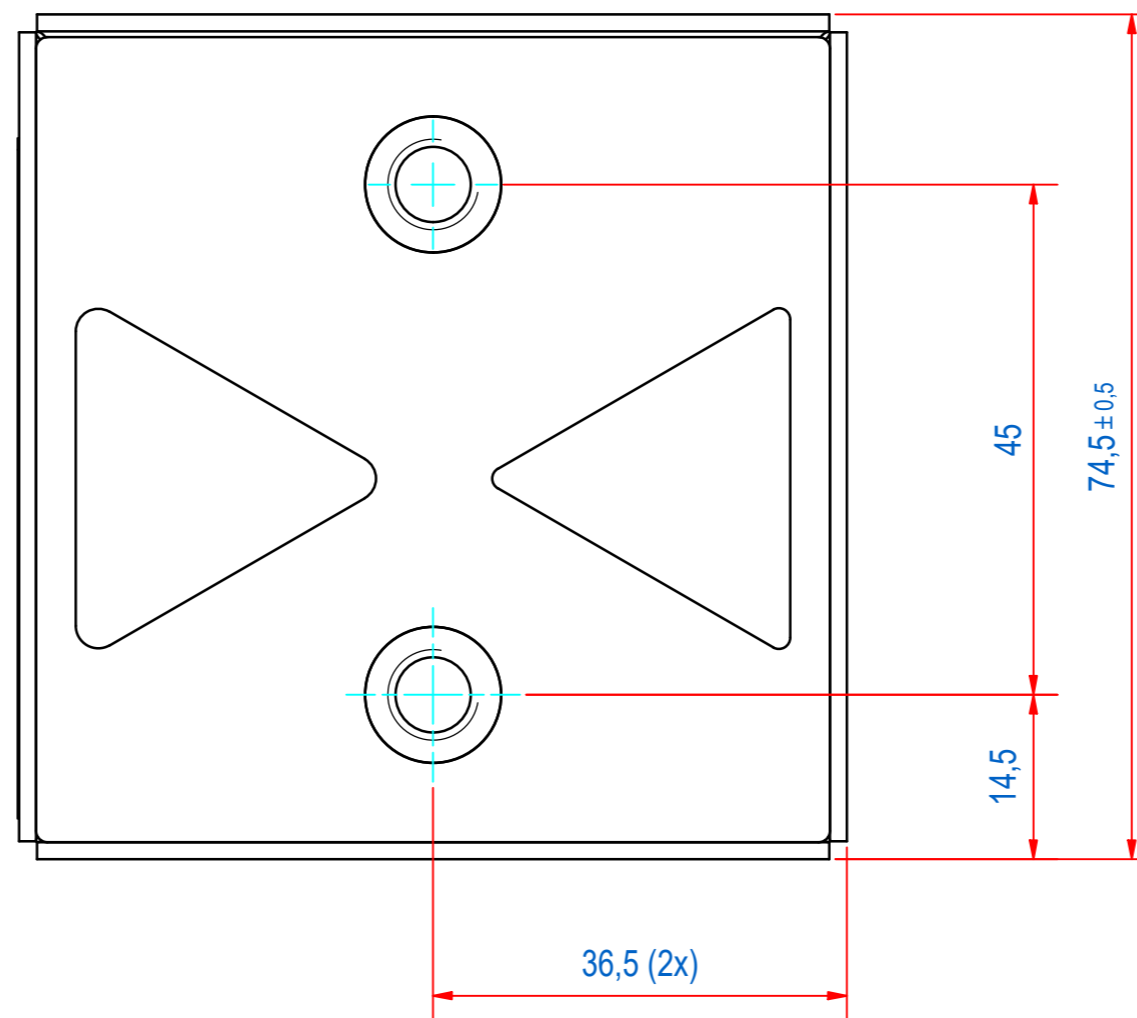
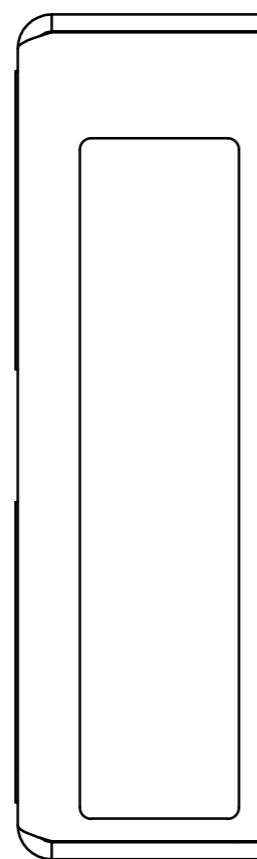
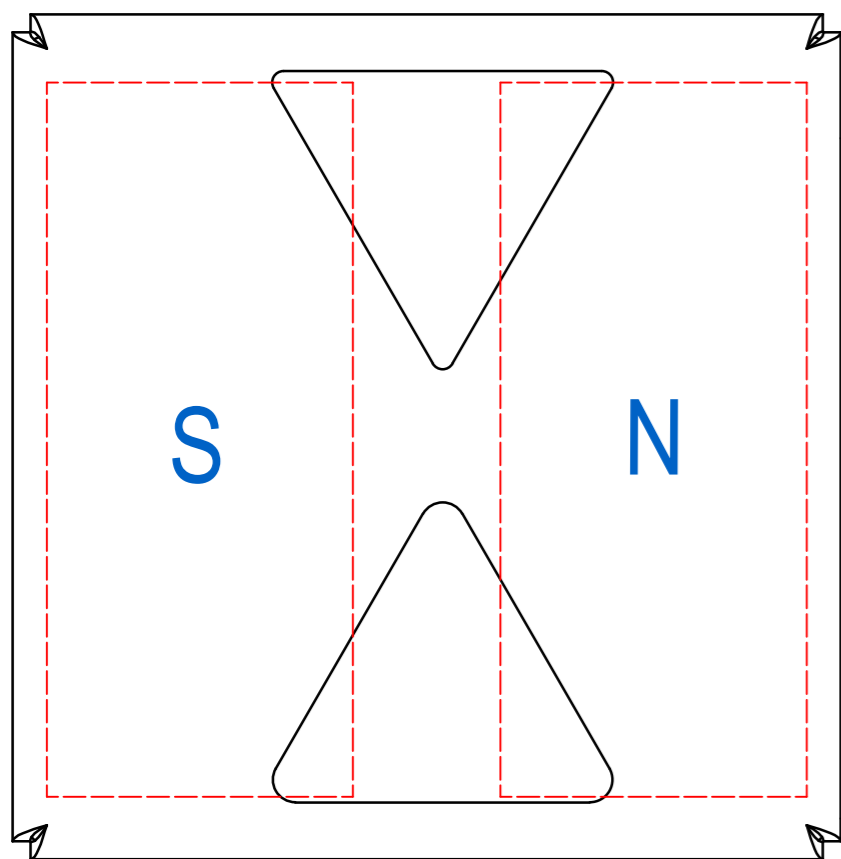

ITEM	QTY	PART NUMBER	DESCRIPTION	Dimensions
4	2	1000.20072	STICKER MAGNET CLAMPING 30mm	
3	2	1000.20027	STICKER MAGNETIC FIELD 30mm	
2	1	E0156689	HSS-TYPE PLATE ETCH	
1	1	E0156370	HSS-WELD AND MOULD ASSY	

RAW MAT.	Quantity	Material Number	Material Description	Length (mm)	Width (mm)
	1				

Sheet: A2	Extra info: SHEET SEPARATOR	General tolerance: ISO 2768 - mK
Drawn: BS	Weight (kg): 1,7	Drawn according: ISO286; ISO1101; ISO2553
Date: 11-6-2014		Status: Standard
Spare part: False	Source: MC-C	Customer reference number:
Quick search: TGSP01		Document number: TGSP010075
Description: HSS-N-BA-073x022-0075-B		Doc.Rev: D
		Part number: TGSP010075
		Rev: D