

REV	DATE	BY	DESCRIPTION
-	27-5-2013	CR	NEW REVISION VAULT, NOTHING CHANGED, OLD REV WAS C
A	8-9-2022	PB	WELD ASSY ADDED

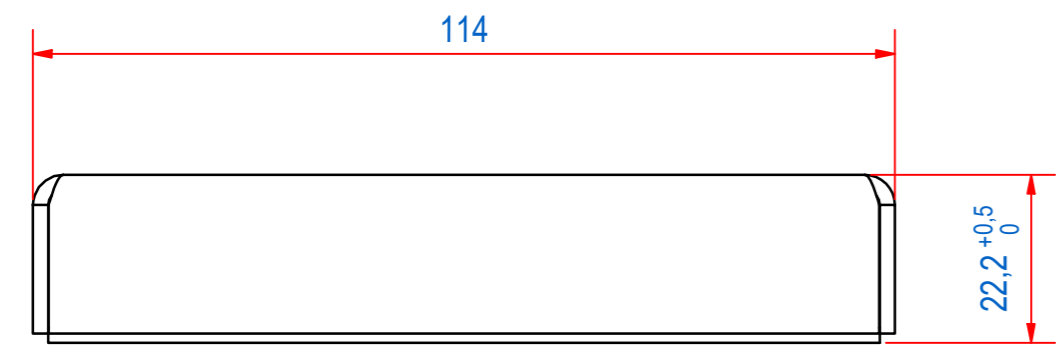
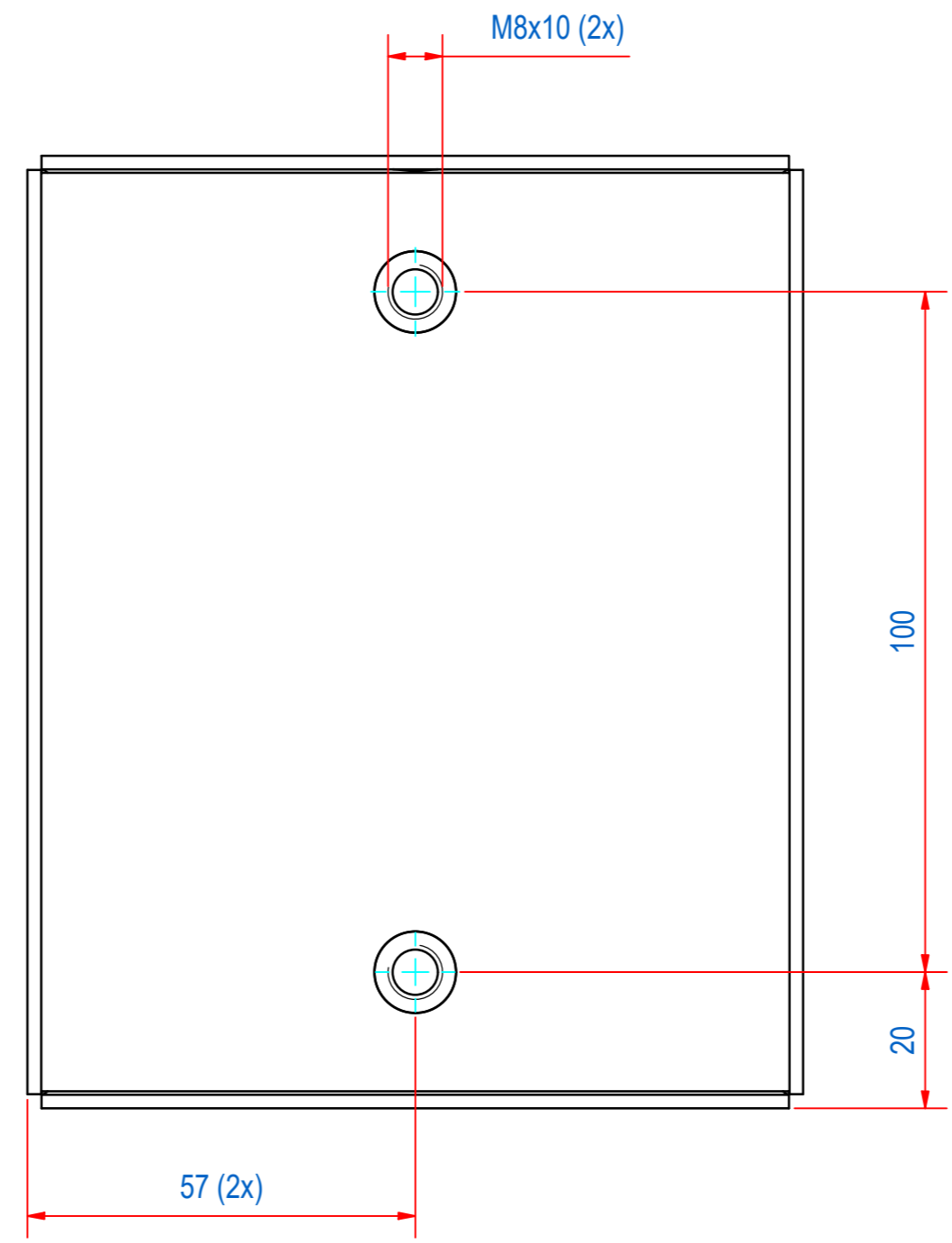
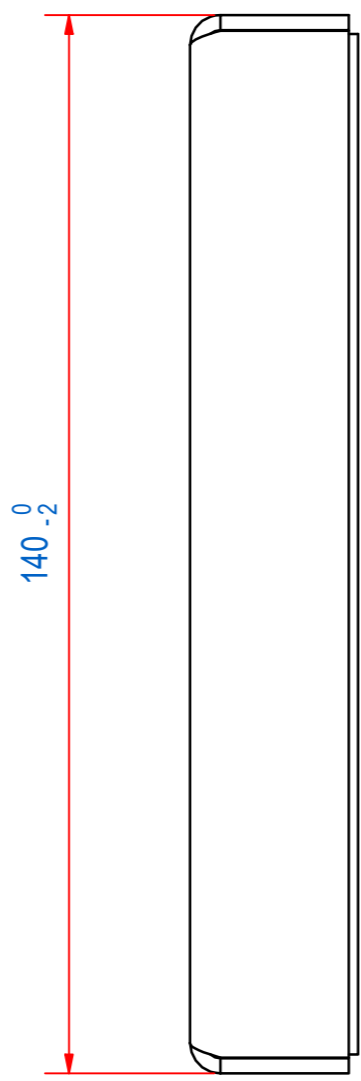
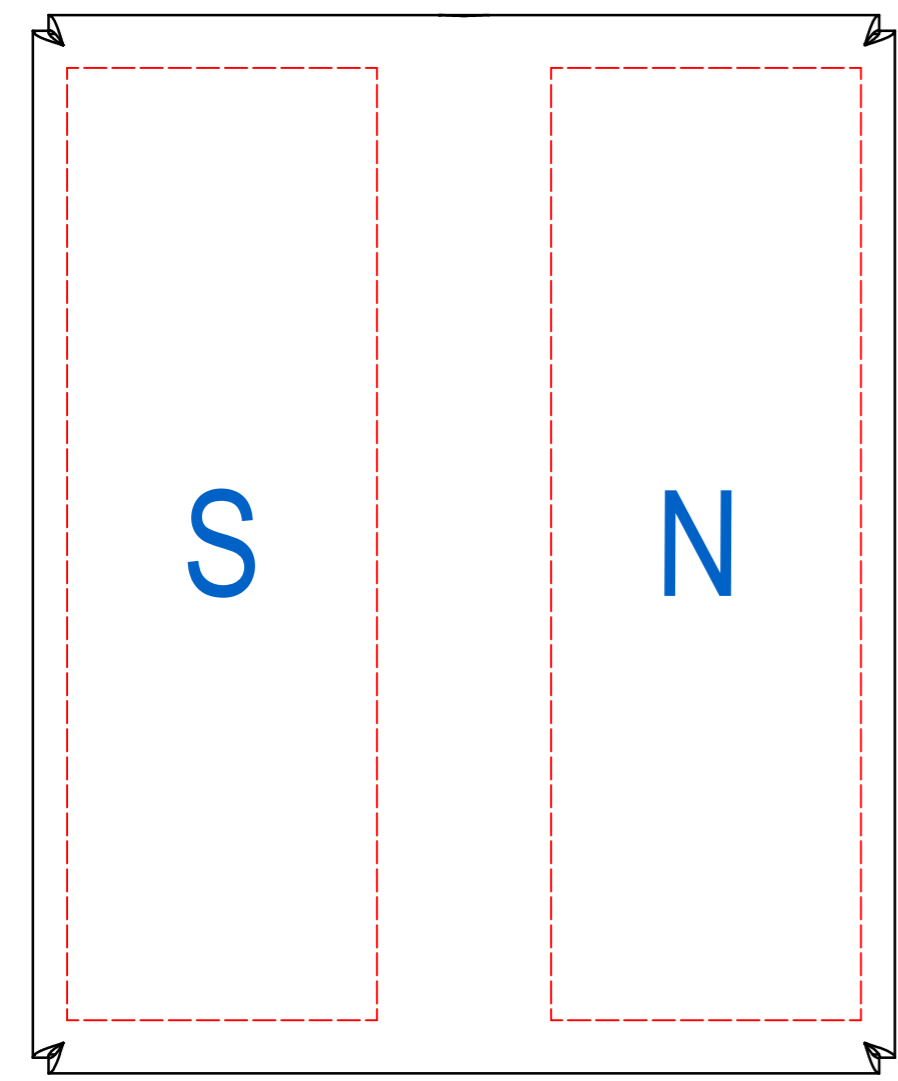
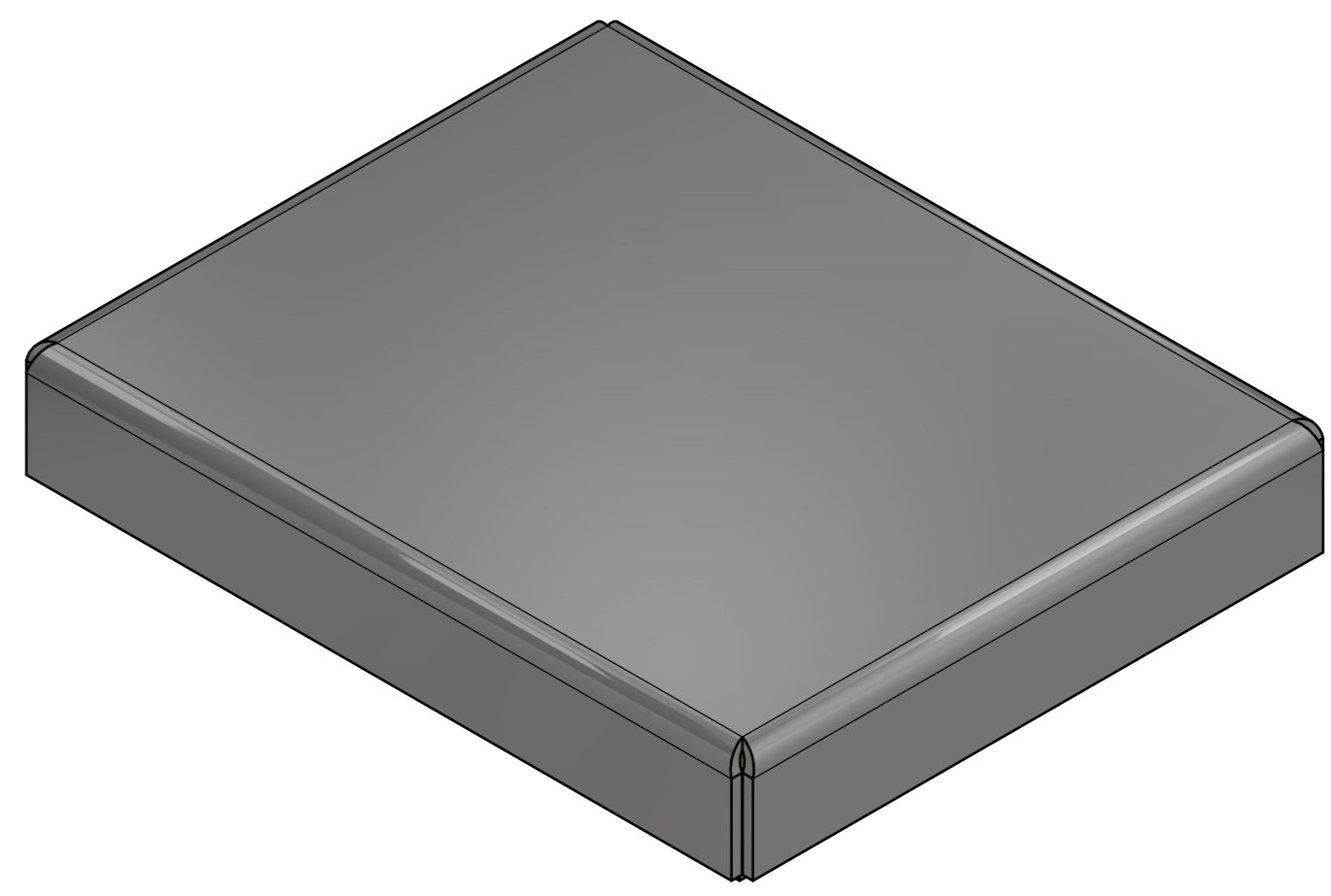

ITEM	QTY	PART NUMBER	DESCRIPTION	Dimensions	
3	1	E0154825	WELD ASSY		
RAW MAT.	1			Length (mm)	Width (mm)
Quantity		Material Number	Material Description	General tolerance: ISO 2768- mK	
Sheet: A2		Extra info: SHEET SEPARATOR		Drawn according: ISO268; ISO1101; ISO2553	
Drawn: AJA		Weight (kg): 3,3		Status: Standard	
Date: 16-6-2004				Customer reference number:	
Spare part: False				Document number: TGSP020140	
Quick search: TGSP02		© All rights reserved. Reproduction is not permitted without written permission of GOUDSMIT Magnetic Systems BV		Part number: TGSP020140	
Description: HSS-N-BA-114x022-0140-B				Rev: A	