

REV	DATE	BY	DESCRIPTION
-	11-3-2013	PB_Admin	NEW VAULT, NEW REVISION. NOTHING CHANGED. OLD REV WAS C
A	20-12-2013	BS	SCREW CAP DESIGN CHANGED, NEW NUMBER (WITH O-RING) IS E0011495
B	17-11-2015	AvD	ITEM 1 CHANGED: E0044571 WAS E0011497

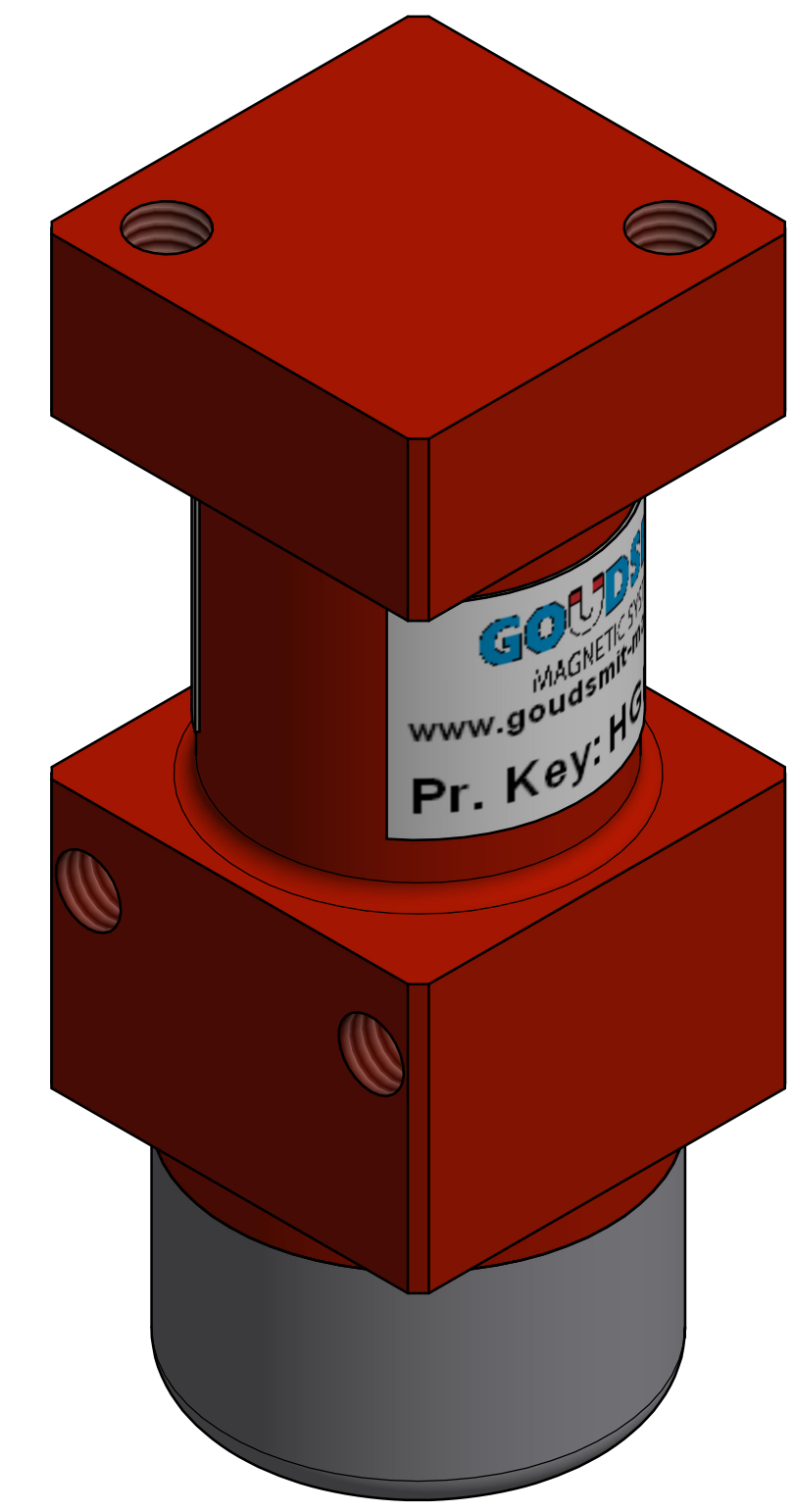
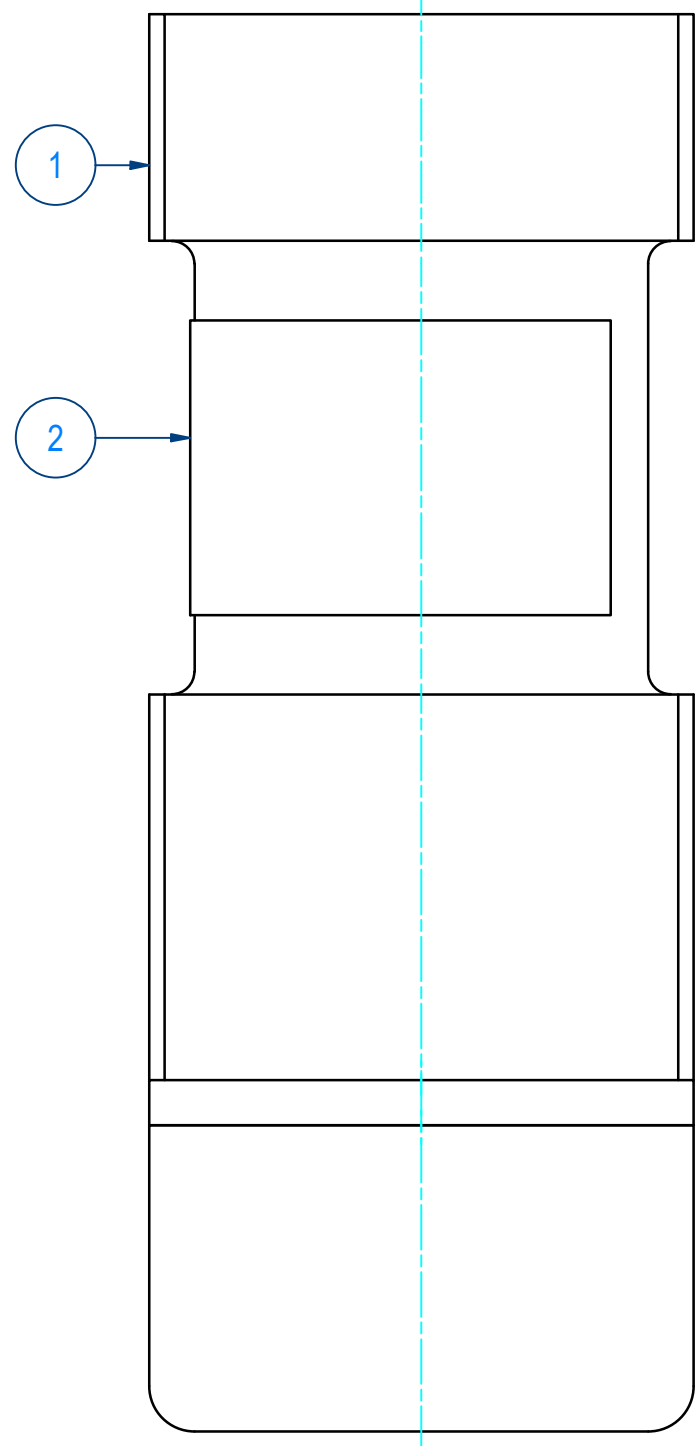
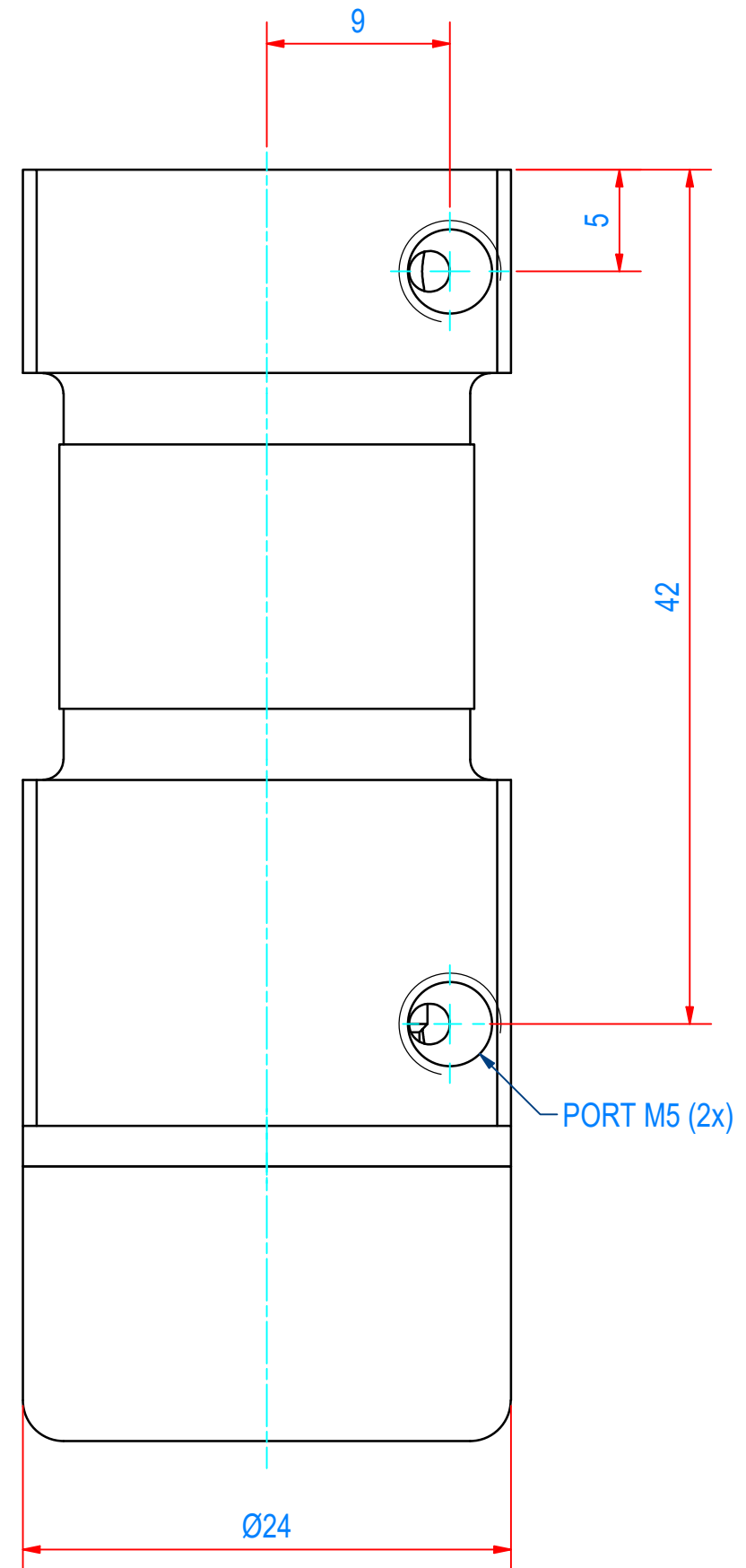
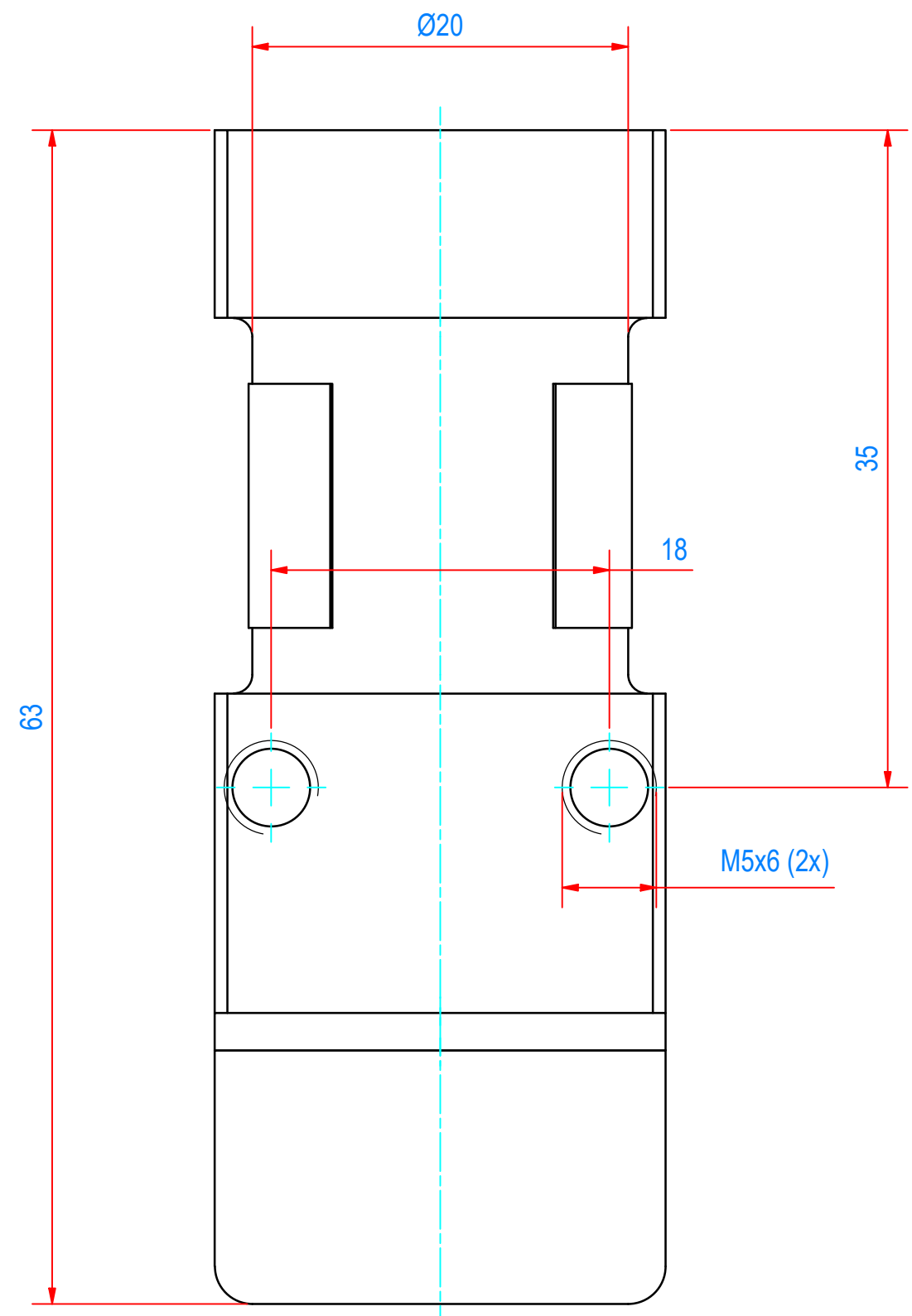
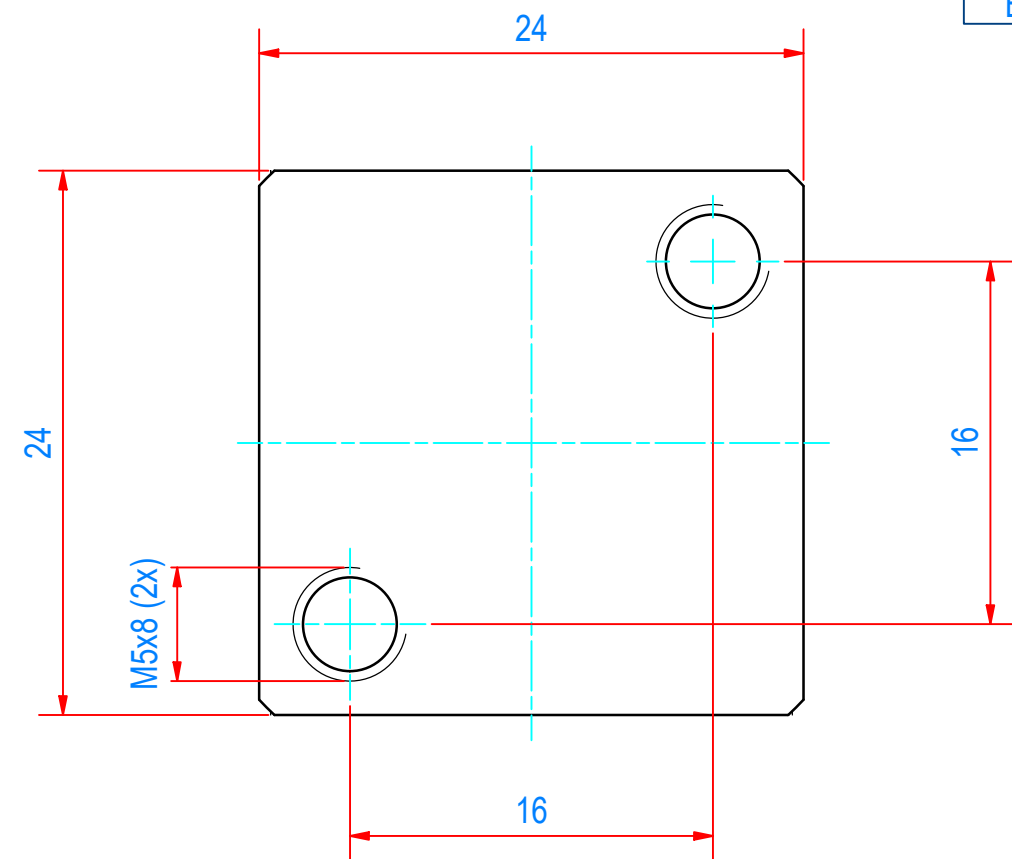

ITEM	QTY	PART NUMBER	DESCRIPTION	Dimensions
2	1	E0037929	STICKER TPGC024078	
1	1	E0044571	MOUNTING ASSY TPGC024078	
RAW MAT.	Quantity	Material Number	Material Description	Length (mm) Width (mm)
	1			
Sheet: A2		Extra info: MAGNETIC GRIPPER		General tolerance: ISO 2768 - mK
Drawn: BS	Weight (kg): 0.078			Drawn according: ISO268; ISO1101; ISO2553
Date: 6-1-2014			Status: Standard	
Spare part: False	Source: MC-C			Customer reference number:
Quick search: TPGC024			Document number: TPGC024078	Doc.Rev: B
Description: HGR-SQ-024-FL-R-M-F			Part number: TPGC024078	Rev: B