

REV	DATE	BY	DESCRIPTION
A	2-1-2014	BS	SCREW CAP DESIGN CHANGED (NEW NUMBER WITH O-RING: E0011622)
B	7-9-2021	PB	SCREW CAP D67 WAS D70
C	15-10-2021	JVe	SCREW CAP D70 WAS D67

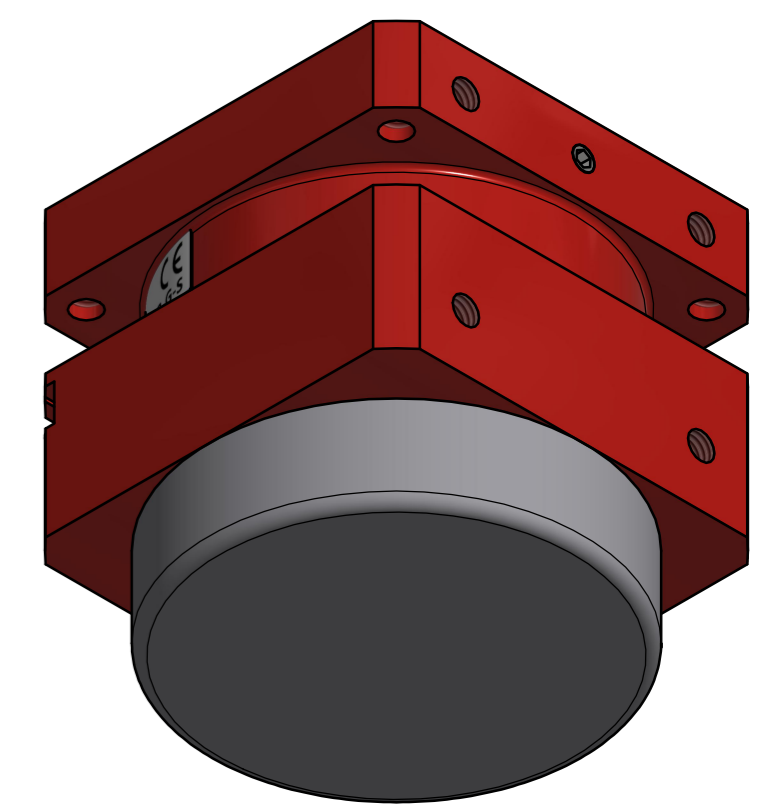
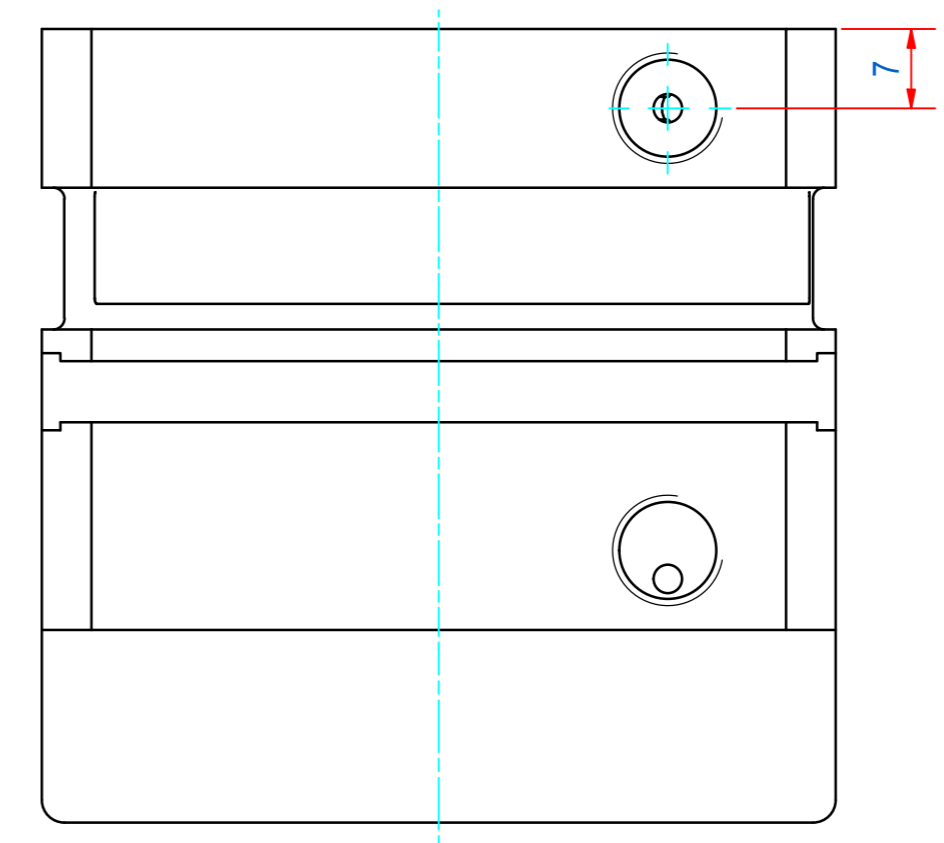
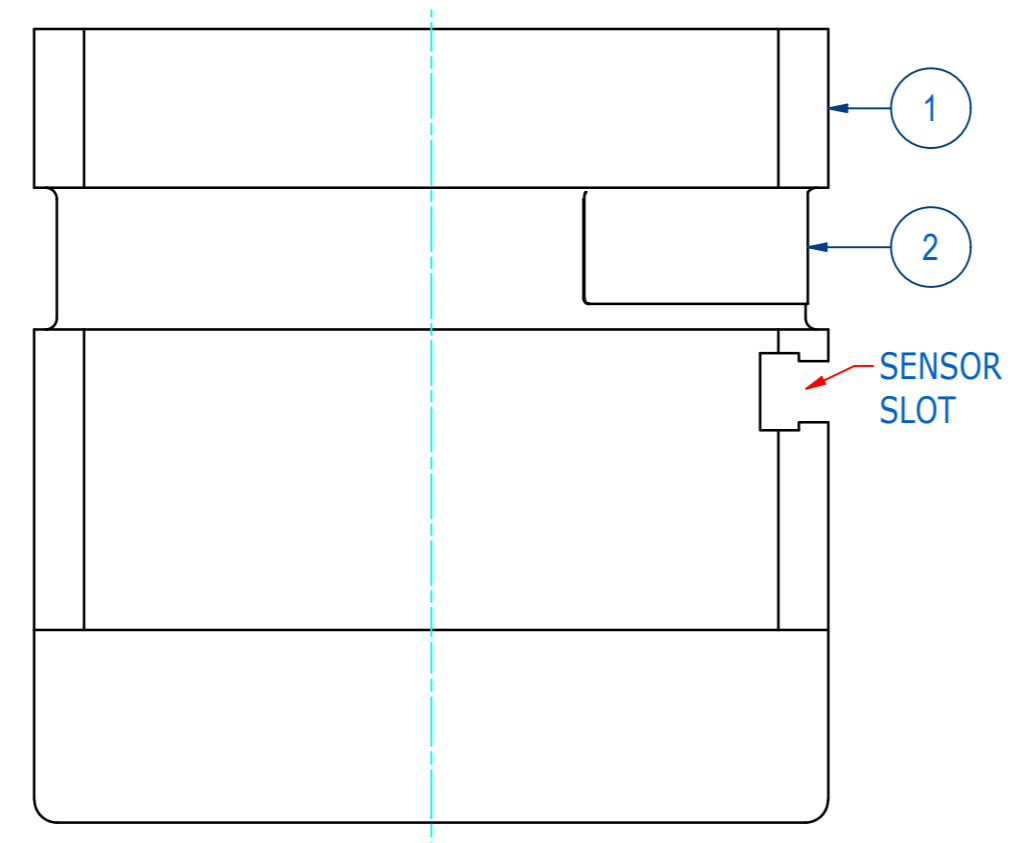
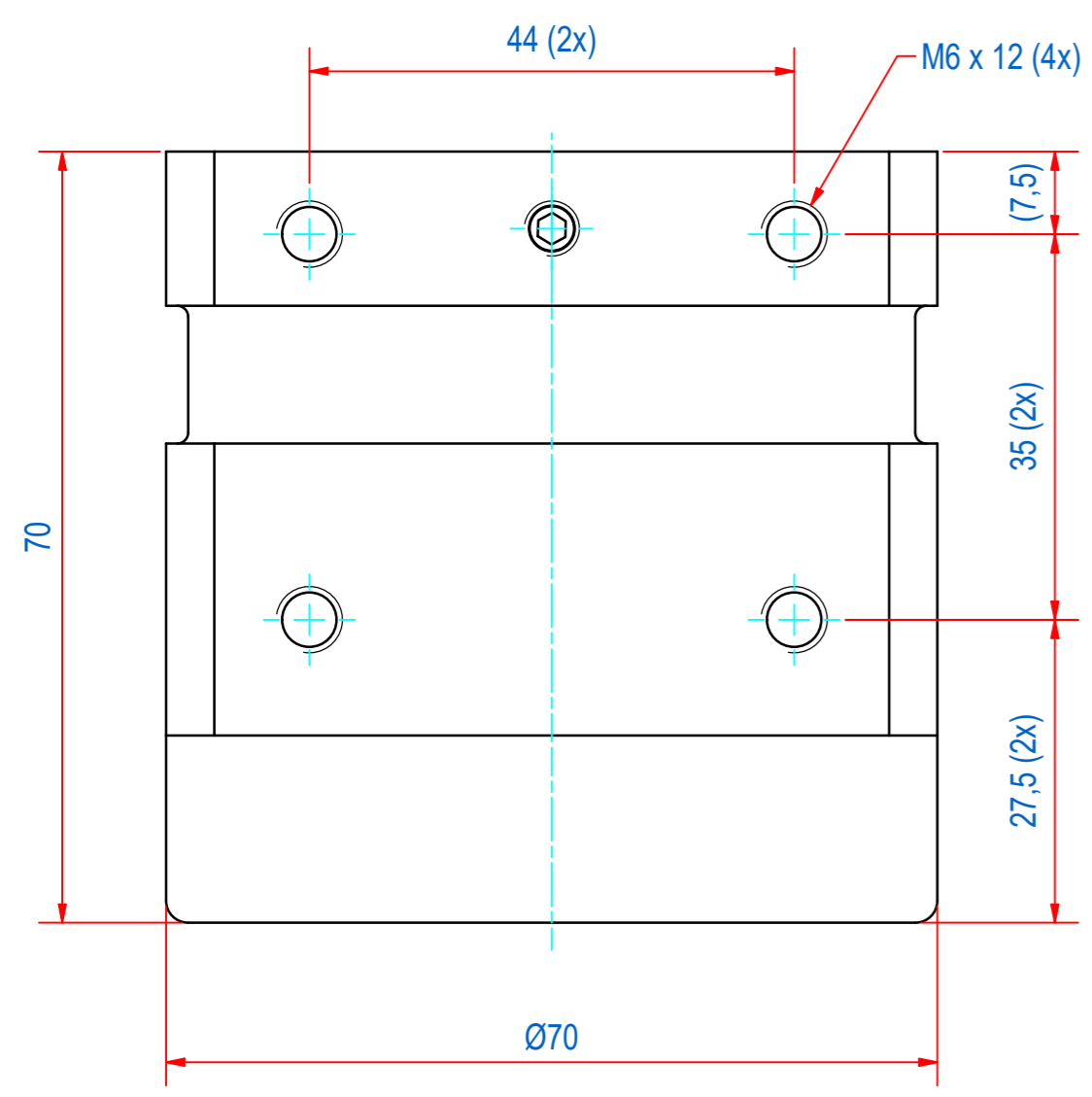
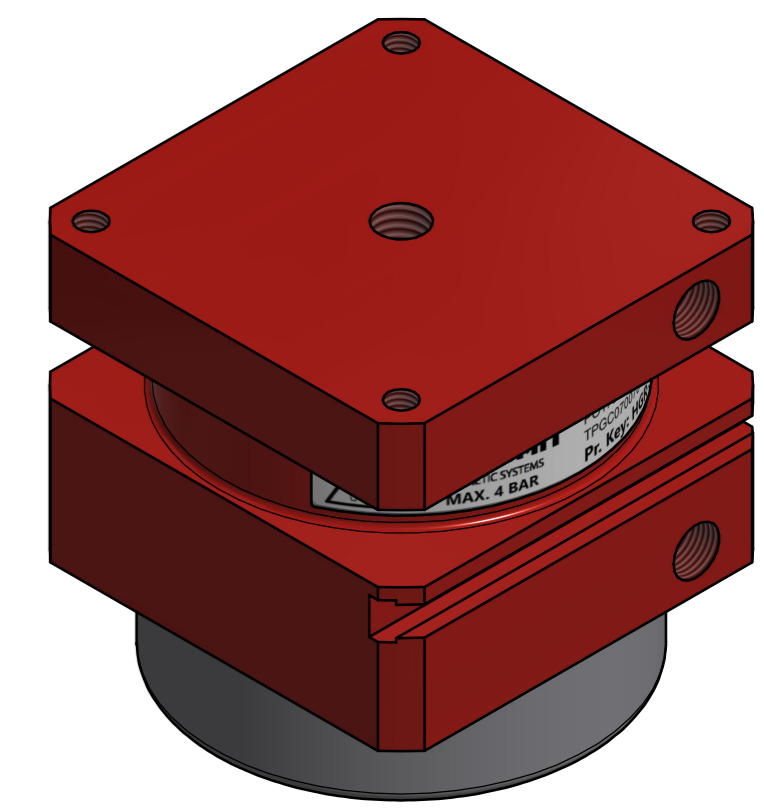
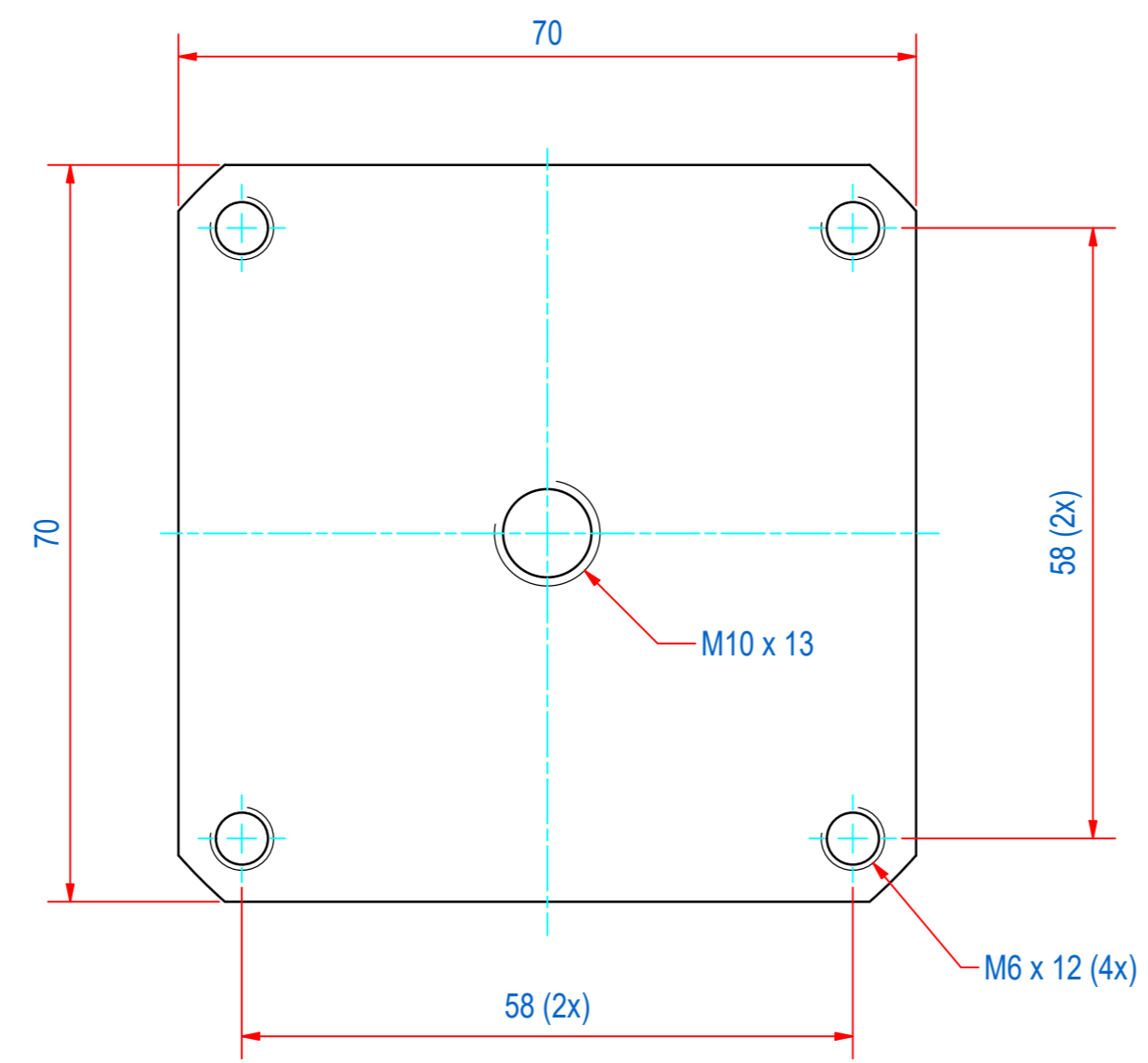

ITEM	QTY	PART NUMBER	DESCRIPTION	Dimensions
2	1	E0038023	HGR-SPARE-STICKER TPGC070078	
1	1	E0011627	MOUNTING ASSY TPGC070	
RAW MAT.	Quantity	Material Number	Material Description	Length (mm) Width (mm)
Sheet: A2		Extra info:		General tolerance: ISO 2768- mK
Drawn: BS		Weight (kg): 0.75		Drawn according: ISO268; ISO1101; ISO2553
Date: 2-1-2014		Source: MC-C		Status: Standard
Spare part: False		Quick search: TPGC070		Customer reference number:
Description: HGR-SQ-070-FL-R-G-S		Part number: TPGC070078		Document number: TPGC070078 Doc.Rev: C
				Rev: C