

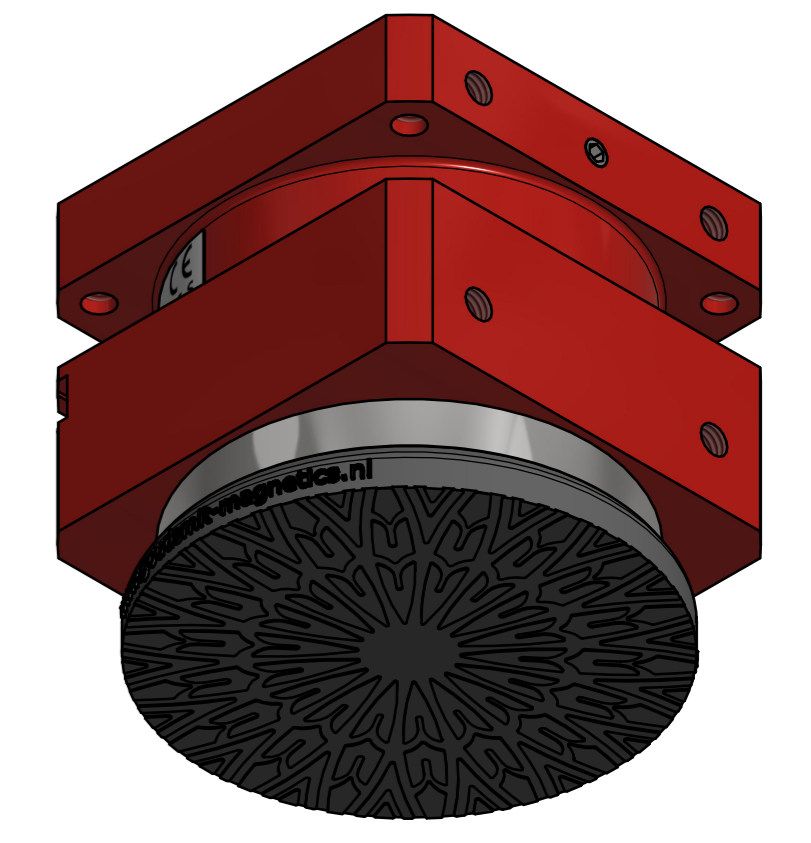

REV	DATE	BY	DESCRIPTION
-	18-12-2013	BS	NEW VAULT, NOTHING CHANGED, IS EQUAL TO OLD REVISION A
A	15-10-2021	JVe	TOP PART SCREW CAP D67 WAS D70, FRICTION PAD HASN'T CHANGED

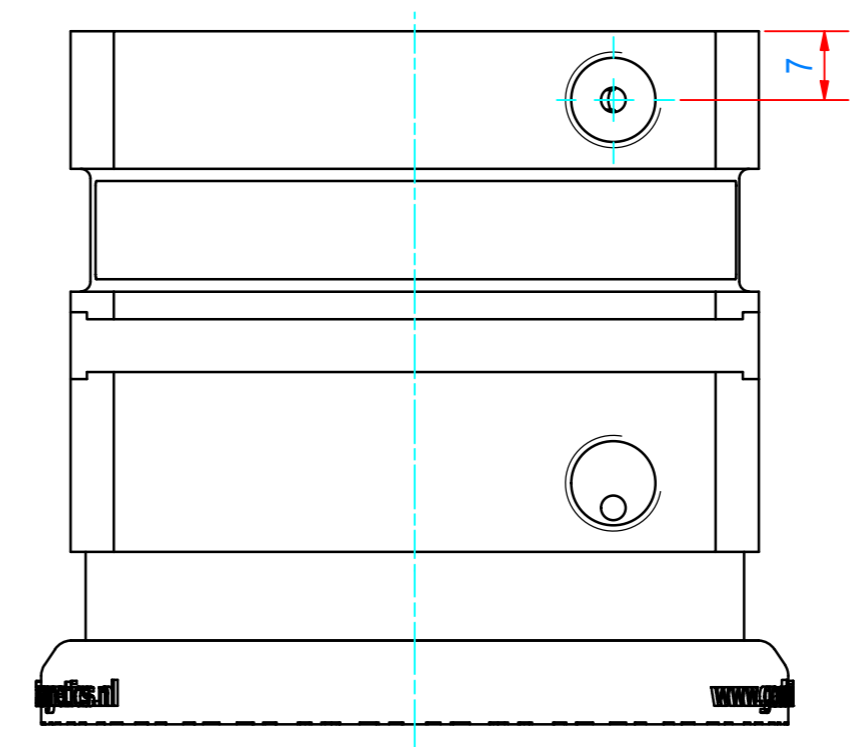
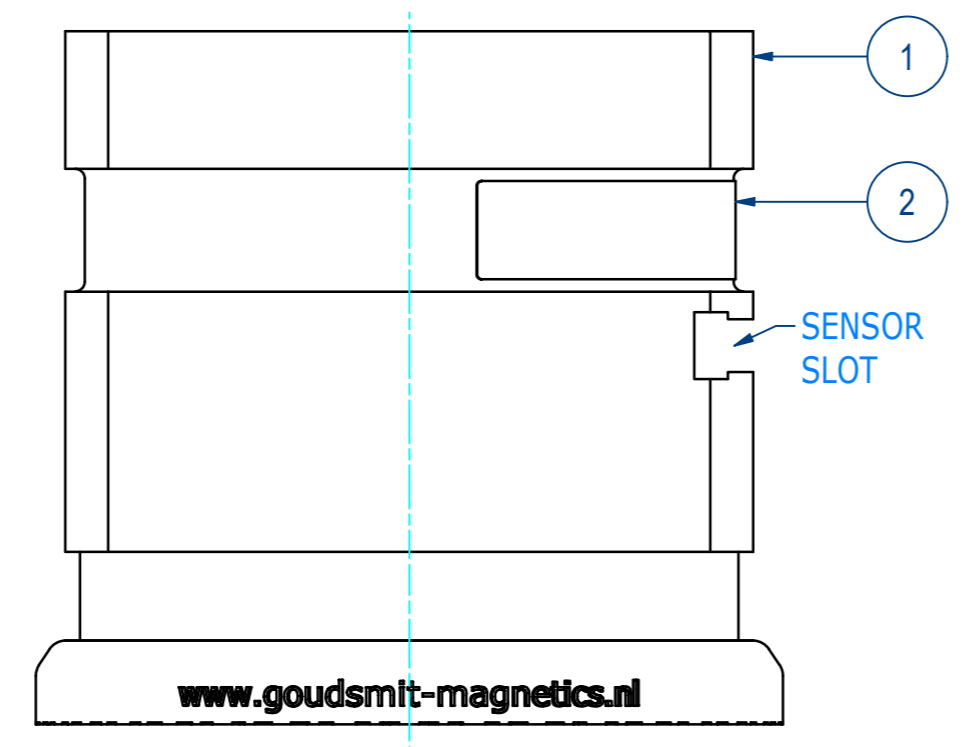
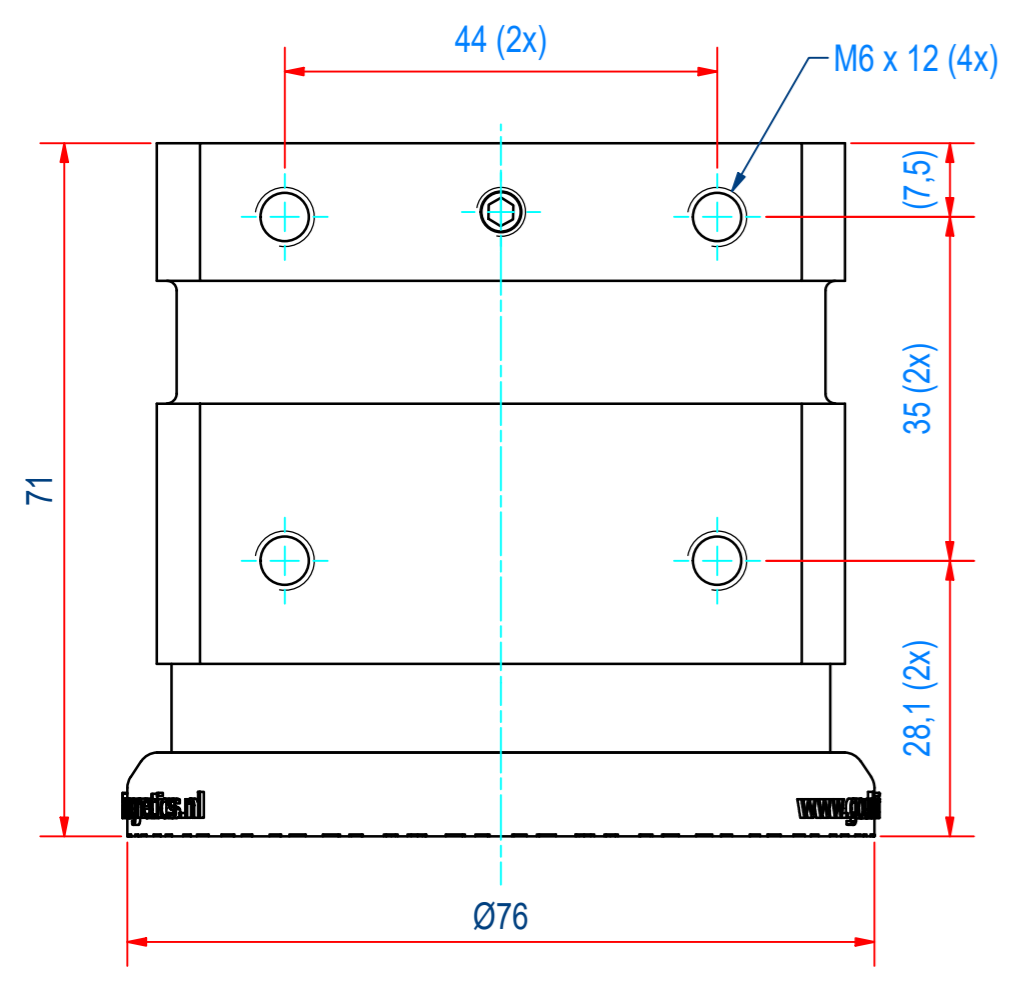
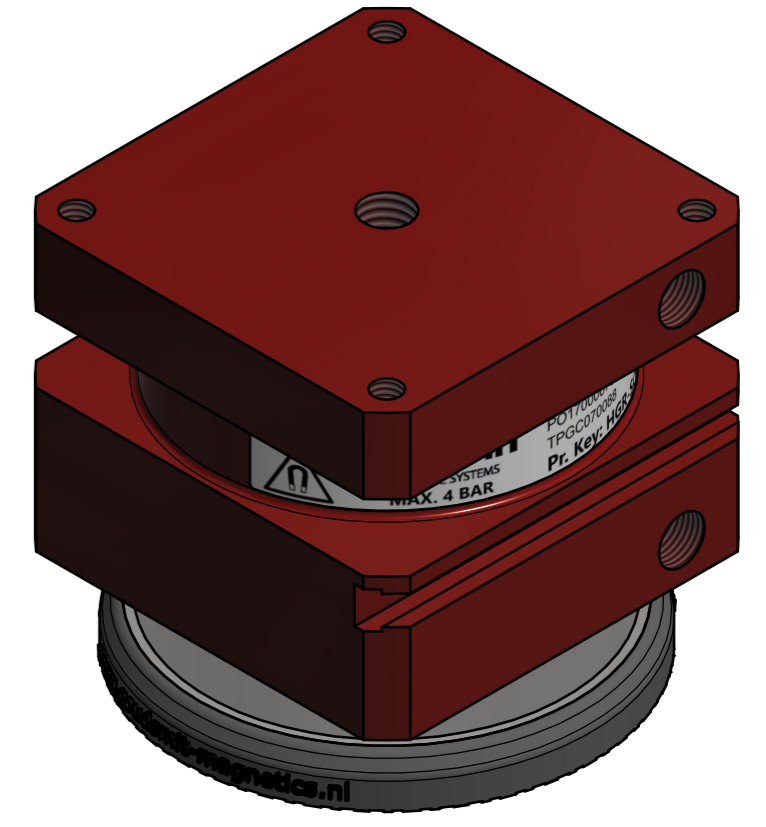
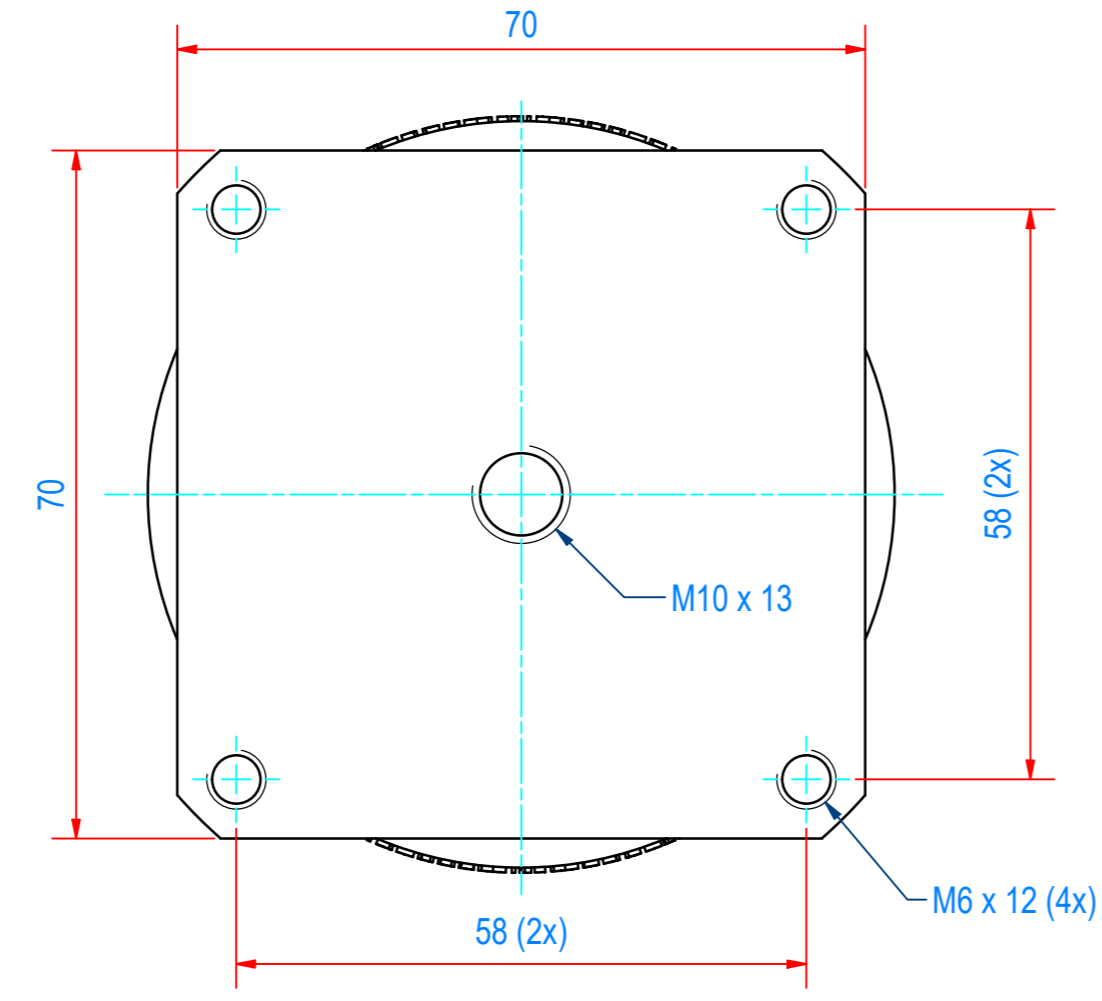

ITEM	QTY	PART NUMBER	DESCRIPTION	Dimensions
2	1	E0038049	STICKER TPGC070088	
1	1	A190243	MOUNTING ASSY TPGC070088	
RAW MAT.	1			
Quantity		Material Number	Material Description	Length (mm) Width (mm)
Sheet:	A2	Extra info:		General tolerance: ISO 2768 - mK
Drawn:	BS	Weight (kg):	0.73	Drawn according: ISO268; ISO1101; ISO2553
Date:	17-12-2013			Status: Standard
Spare part:	False	Source:	MC-C	Customer reference number:
Quick search:	TPGC070			Document number: TPGC070088 Doc.Rev: A
Description:	HGR-SQ-070-FP-R-G-S			Part number: TPGC070088 Rev: A