

REV	DATE	BY	DESCRIPTION
-	6-5-2013	BS	NOTHING CHANGED, OLD REVISION C
A	6-1-2014	BS	SCREW CAP DESIGN CHANGED, NEW NUMBER WITH O-RING: E0011674

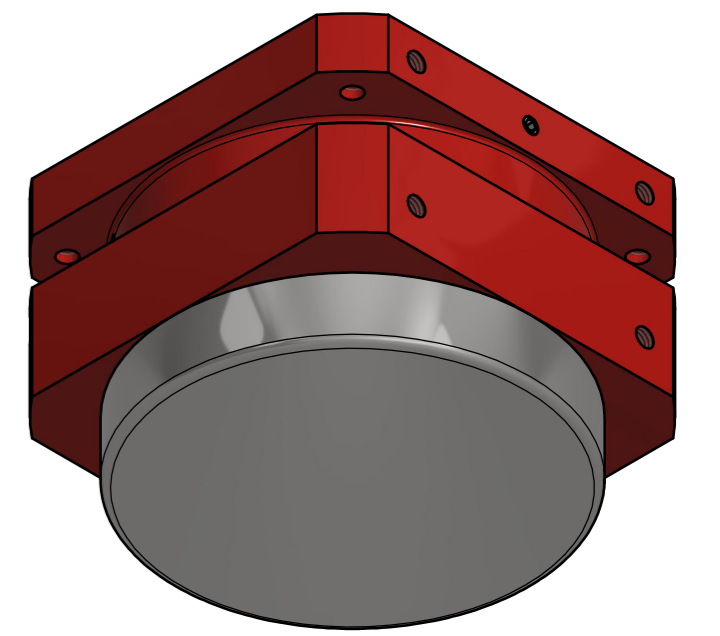
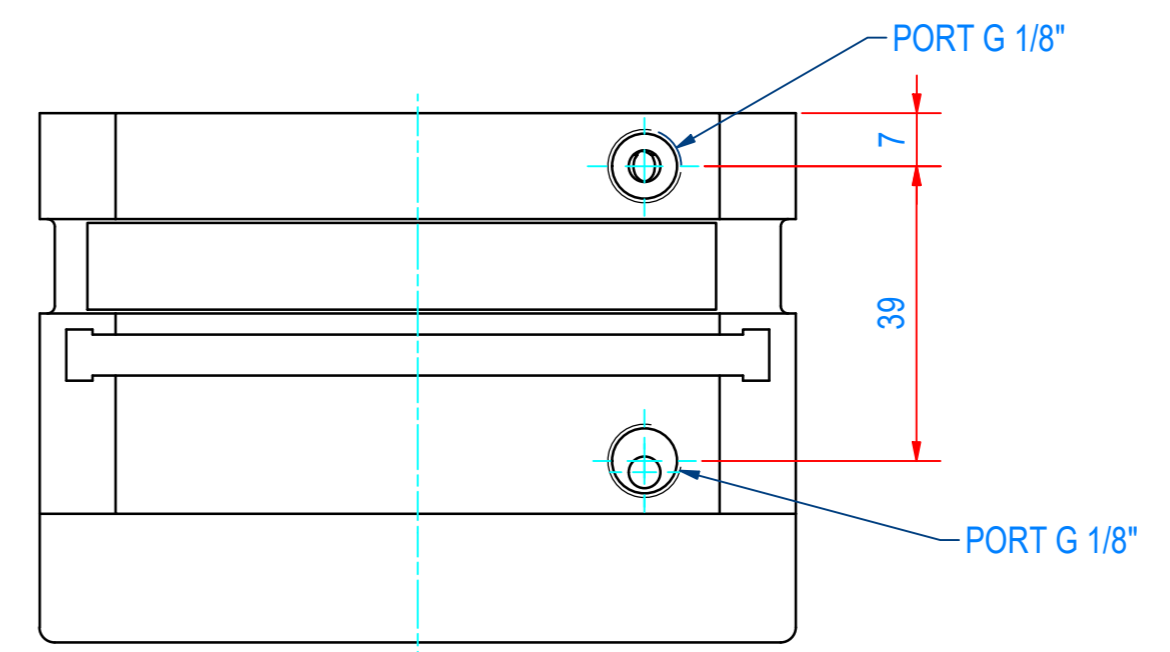
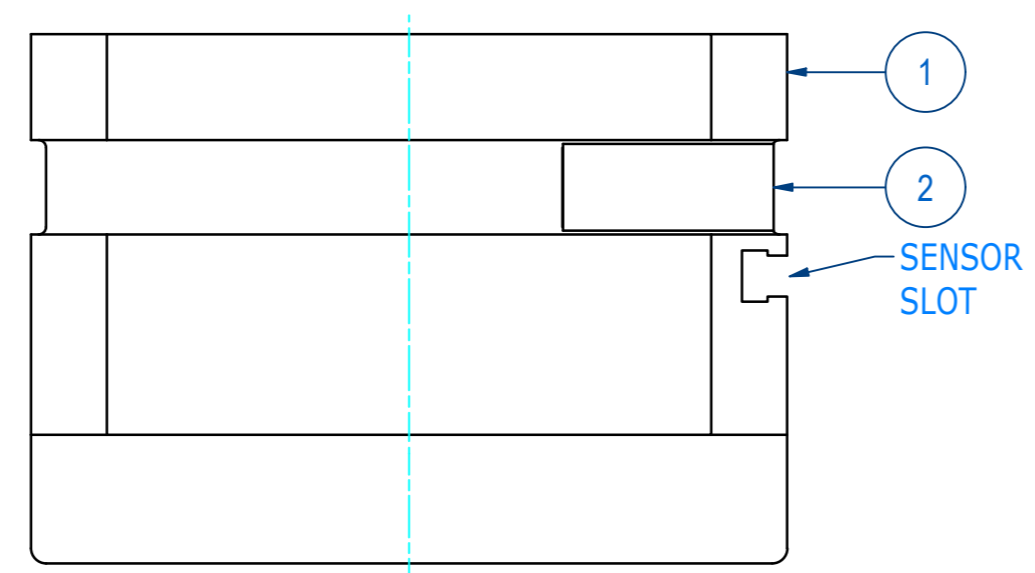
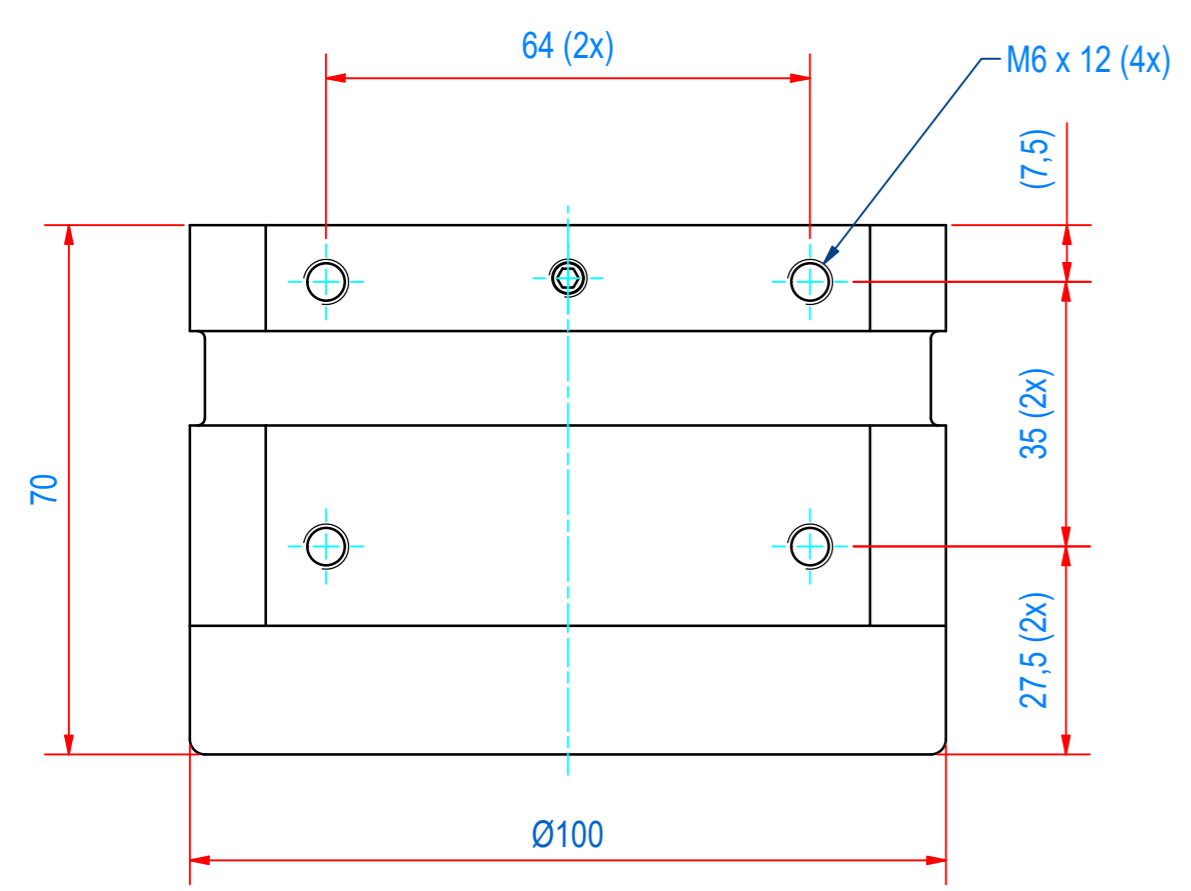
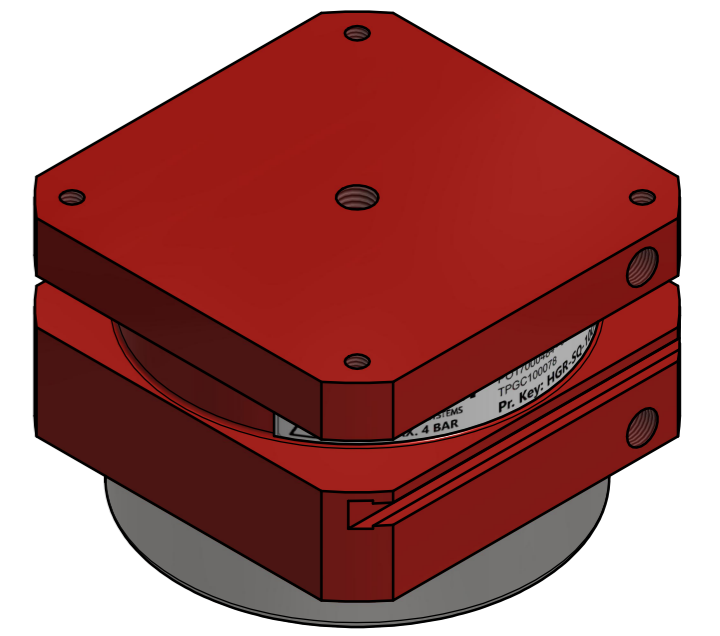
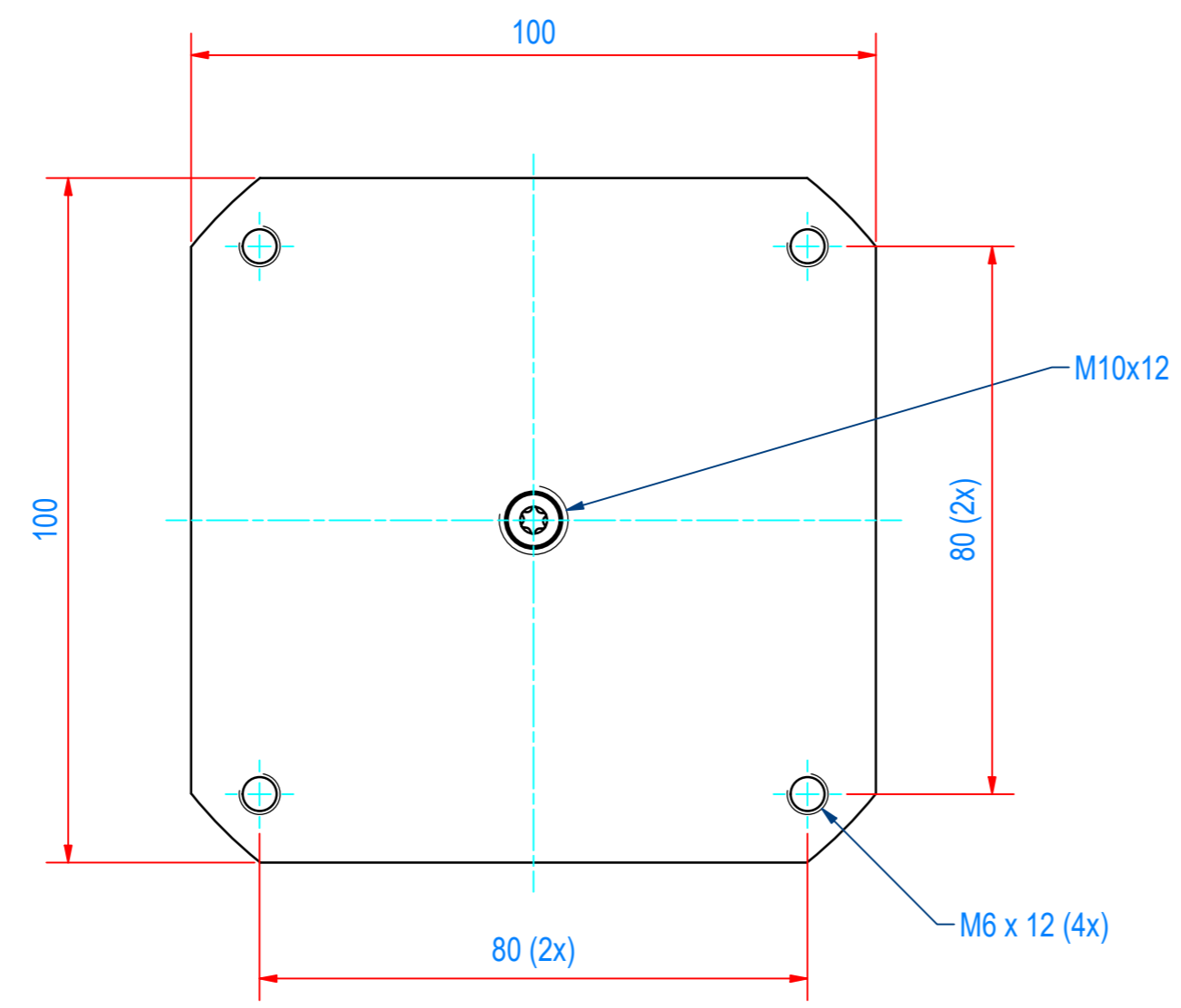

ITEM	QTY	PART NUMBER	DESCRIPTION	Dimensions
2	1	E0038028	HGR-SPARE-STICKER TPGC100078	
1	1	E0011675	MOUNTING ASSY	
RAW MAT.	1			
Quantity		Material Number	Material Description	Length (mm) Width (mm)
Sheet:	A2	Extra info:	General tolerance:	ISO 2768- mK
Drawn:	BS	Weight (kg):	1.5	Drawn according:
Date:	11-6-2009			ISO268; ISO1101; ISO2553
Spare part:	False	Source:		Status:
Quick search:	TPGC100			Standard
Description:	HGR-SQ-100-FL-R-G-S			Customer reference number:
				Document number:
				TPGC100078
				Doc.Rev:
				A
				Part number:
				TPGC100078
				Rev:
				A