

REV	DATE	BY	DESCRIPTION
-	18-12-2013	BS	NEW VAULT, NOTHING CHANGED, IS EQUAL TO OLD REVISION A

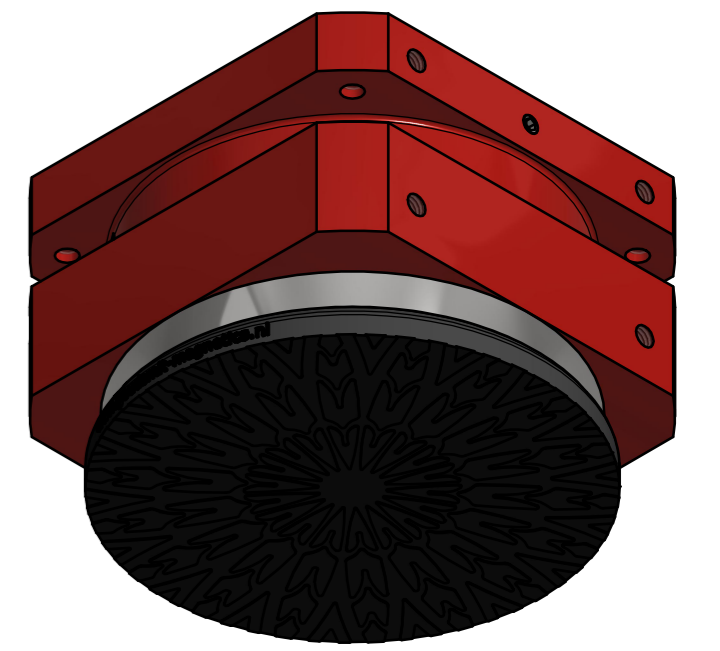
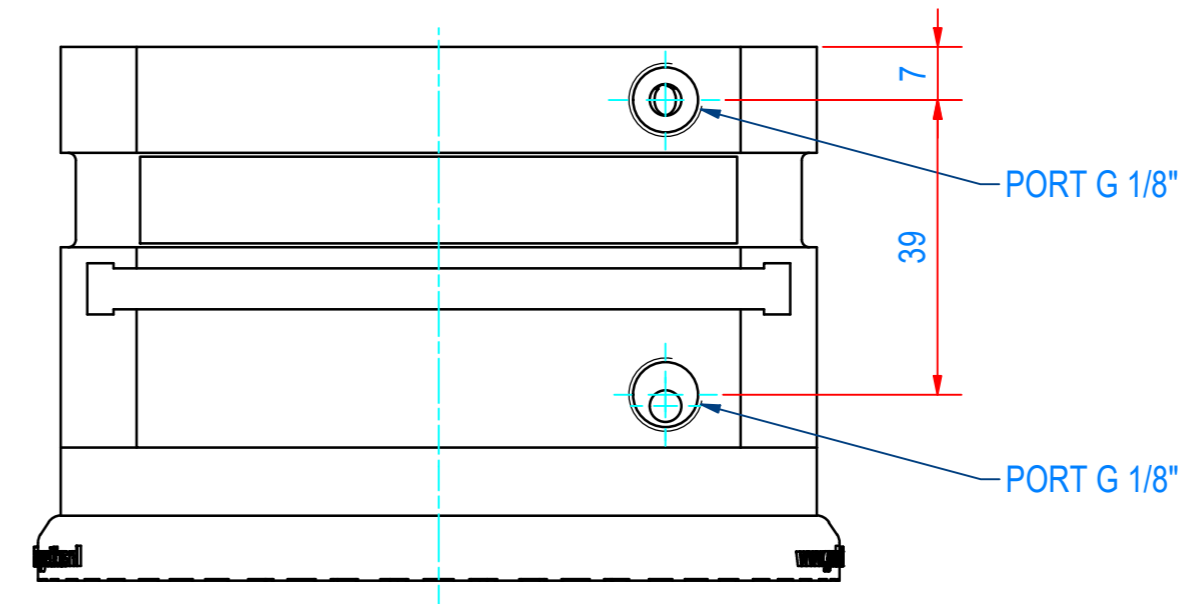
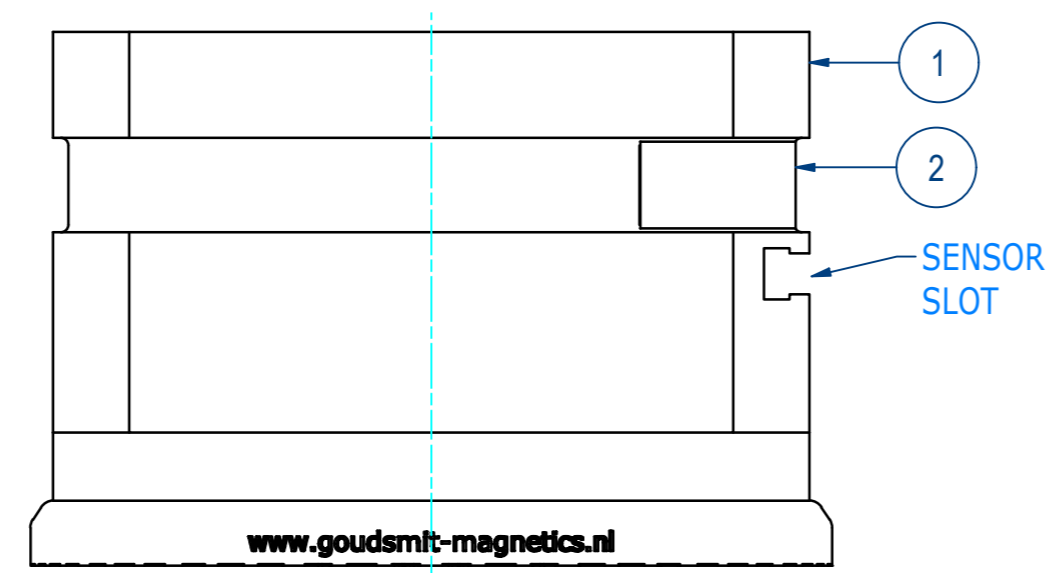
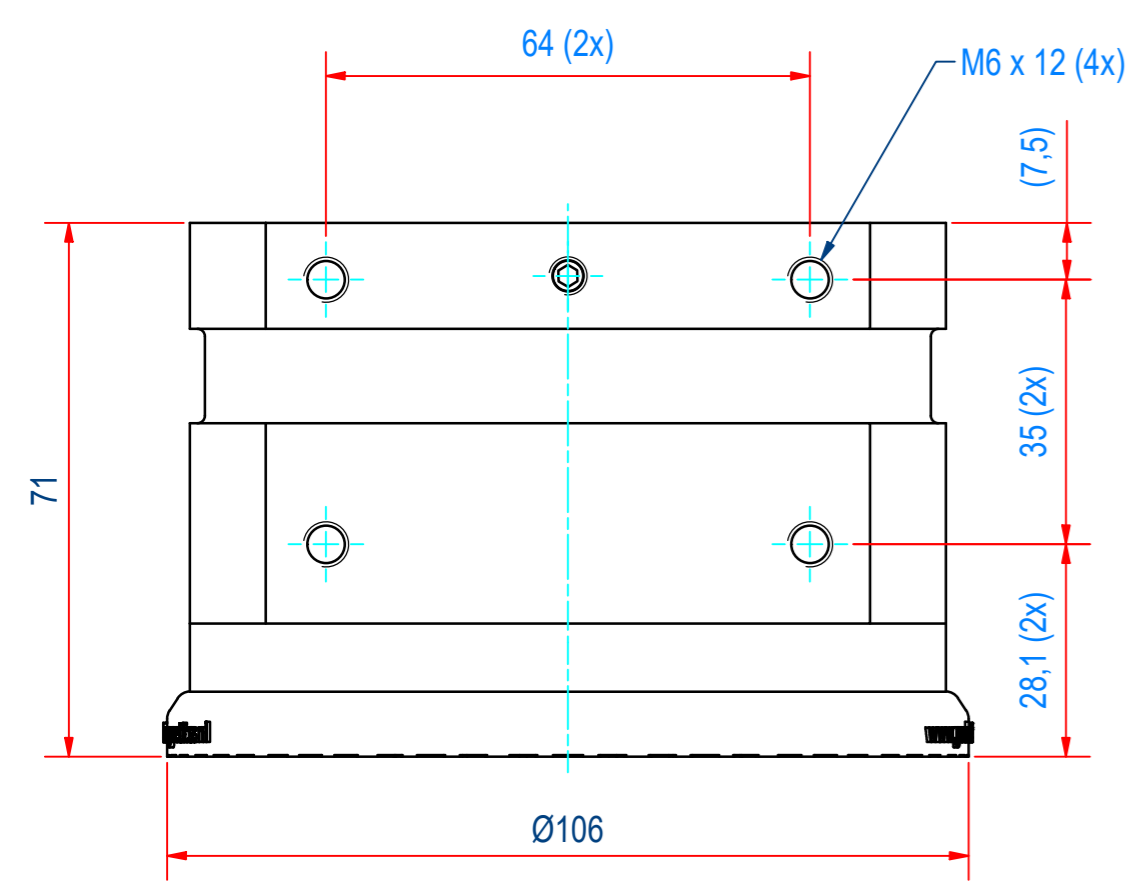
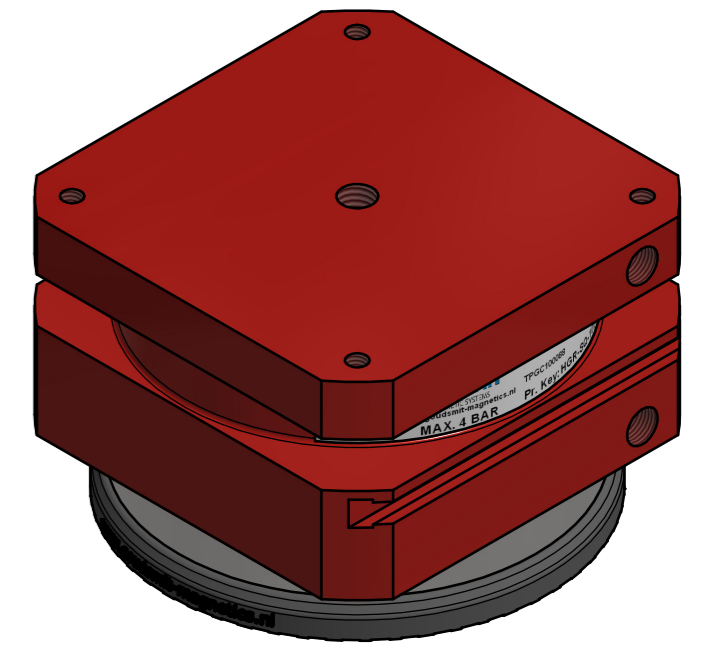
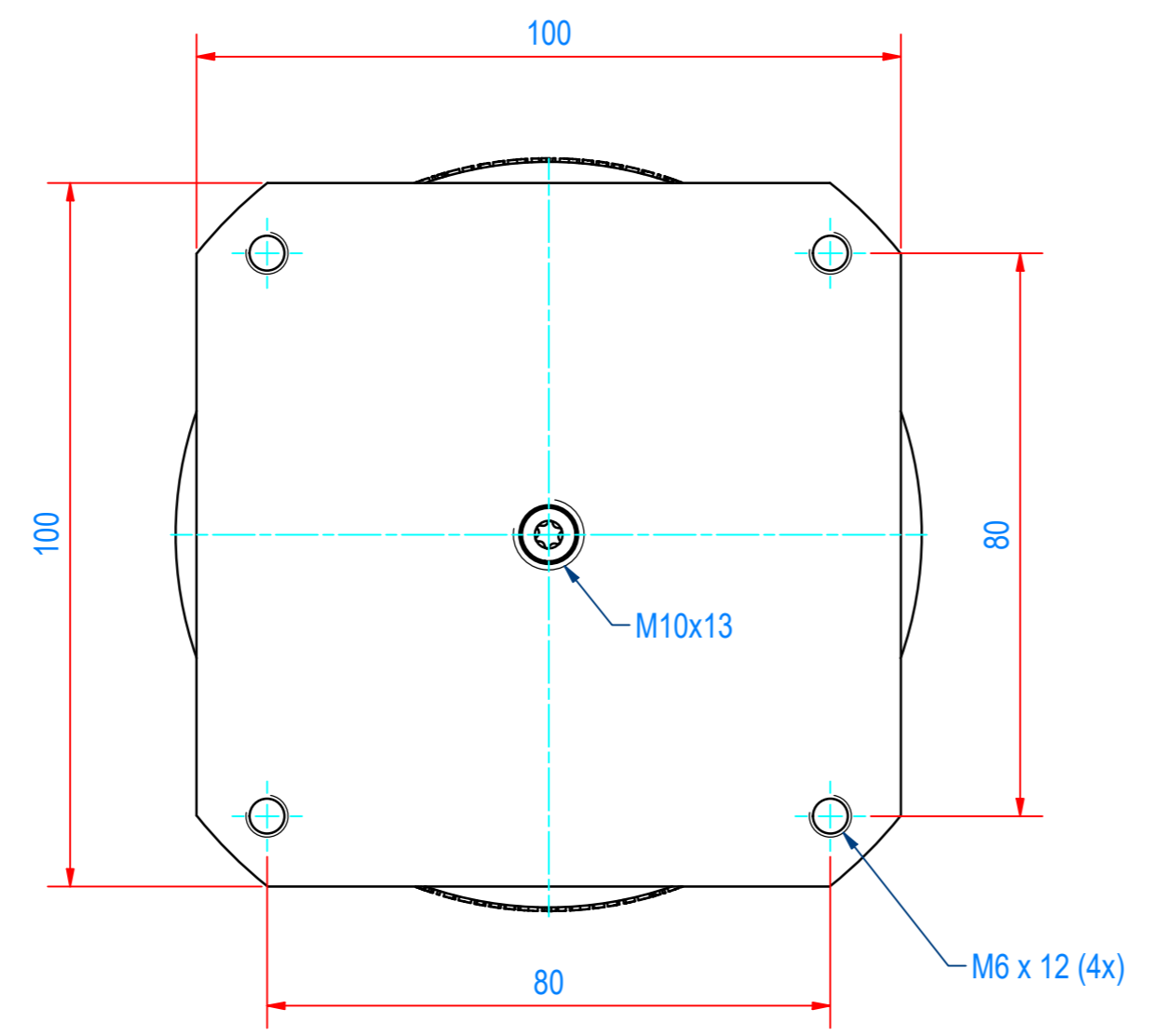

ITEM	QTY	PART NUMBER	DESCRIPTION	Dimensions
2	1	E0038051	STICKER TPGC100088	
1	1	A190306	MOUNTING ASSY TPGC100088	
RAW MAT.	1			
Quantity		Material Number	Material Description	Length (mm) Width (mm)
Sheet:	A2	Extra info:	General tolerance:	ISO 2768- mK
Drawn:	BS	Weight (kg):	1.5	Drawn according:
Date:	17-12-2013	Source:	MC-C	ISO268; ISO1101; ISO2553
Spare part:	False	Quick search:	TPGC100	Status:
Description:	HGR-SQ-100-FP-R-G-S			Standard
			Customer reference number:	
			Document number:	TPGC100088
			Part number:	TPGC100088
			Doc.Rev:	
			Rev:	