

REV	DATE	BY	DESCRIPTION
A	10-7-2014	PB	E0018884 WAS A190495.
B	11-2-2022	GS	E0150205 WAS E0018884
C	14-2-2022	GS	E0018884 WAS E0150205 (BACK TO STATUS REV. A)

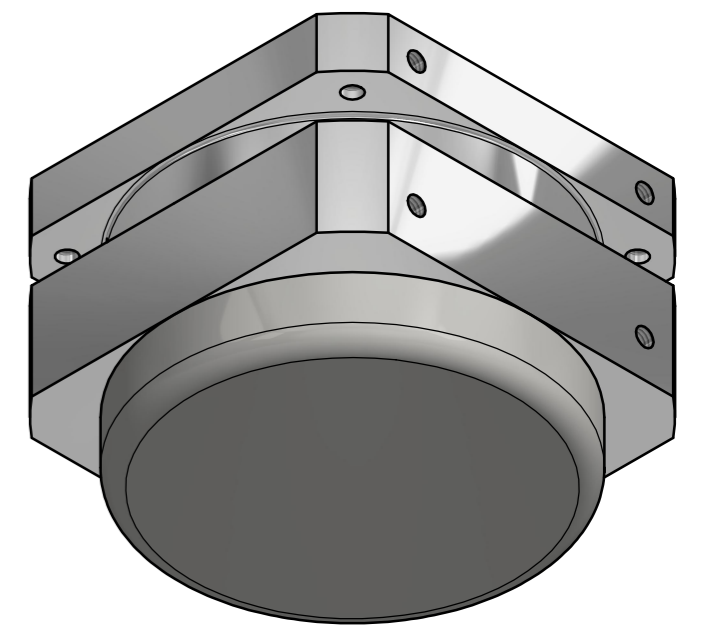

ITEM	QTY	PART NUMBER	DESCRIPTION	Dimensions
2	1	E0038043	STICKER TPGC100078	
1	1	E0018884	MOUNTING ASSY TPGC100HT	
RAW MAT.	1			
Quantity		Material Number	Material Description	Length (mm) Width (mm)
Sheet:	A2	Extra info:	AMBIENT TEMP. MAX.120°C	
Drawn:	PB	Weight (kg):	1.5	
Date:	10-7-2014	General tolerance:	ISO 2768- mK	
Spare part:	False	Source:	MC-C	
Quick search:	TPGC100	Drawn according:	ISO268; ISO1101; ISO2553	
Description:	HGR-SQ-100-FL-RH-G-F	Status:	Standard	
		Customer reference number:		
		Document number:	TPGC100378	Doc.Rev: C
		Part number:	TPGC100378	Rev: C

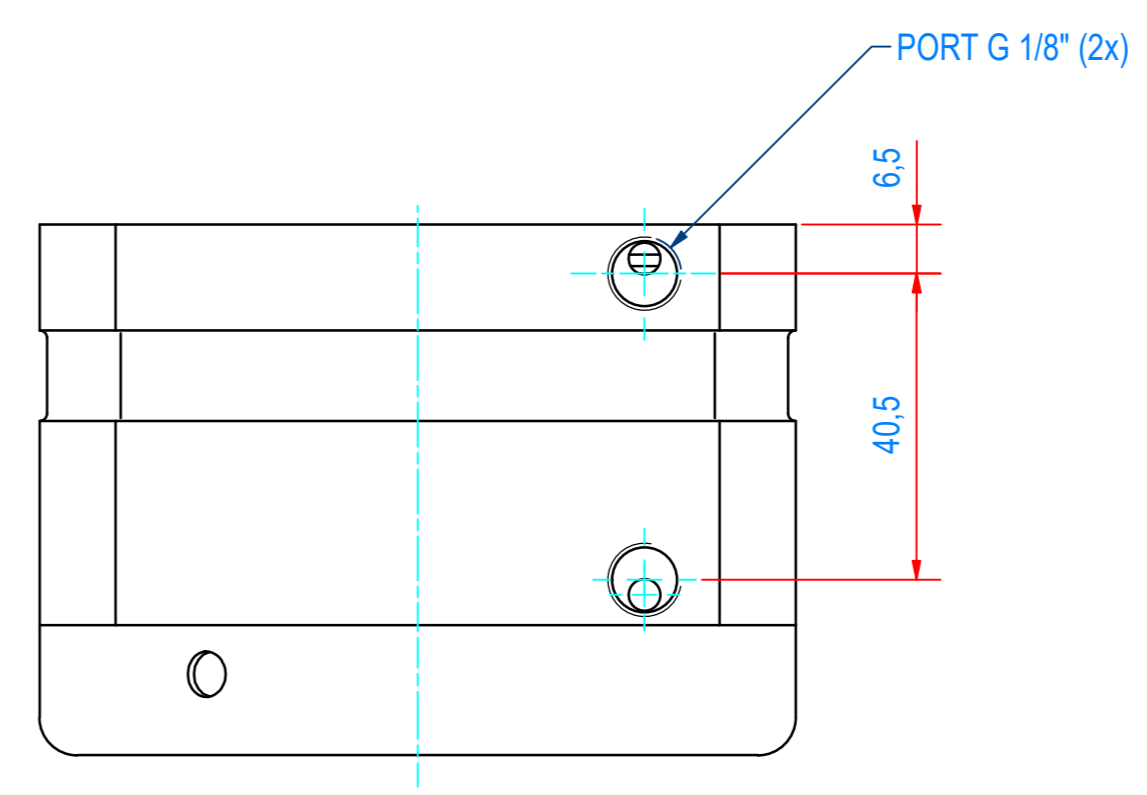
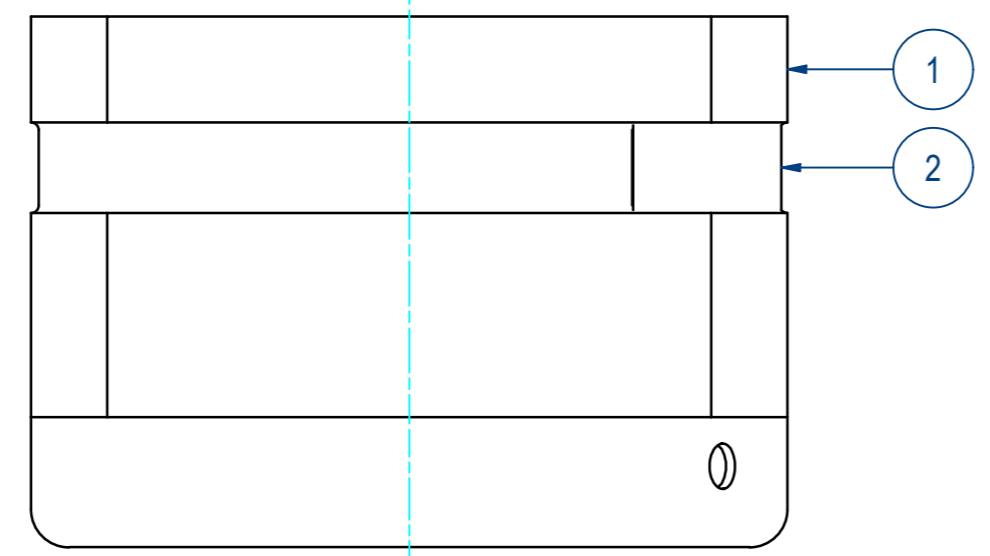
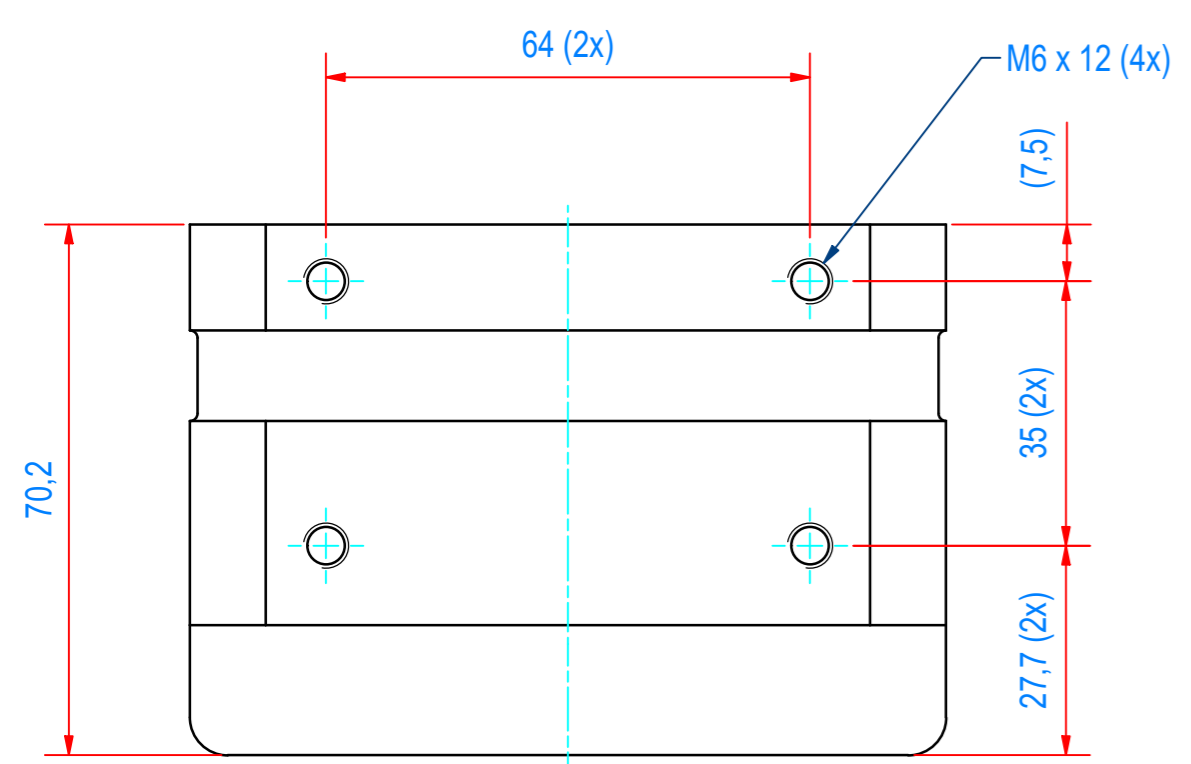
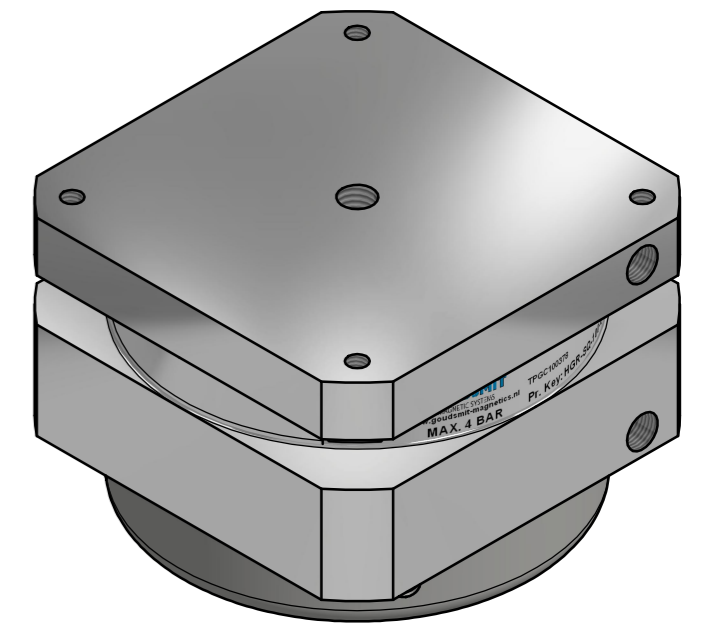
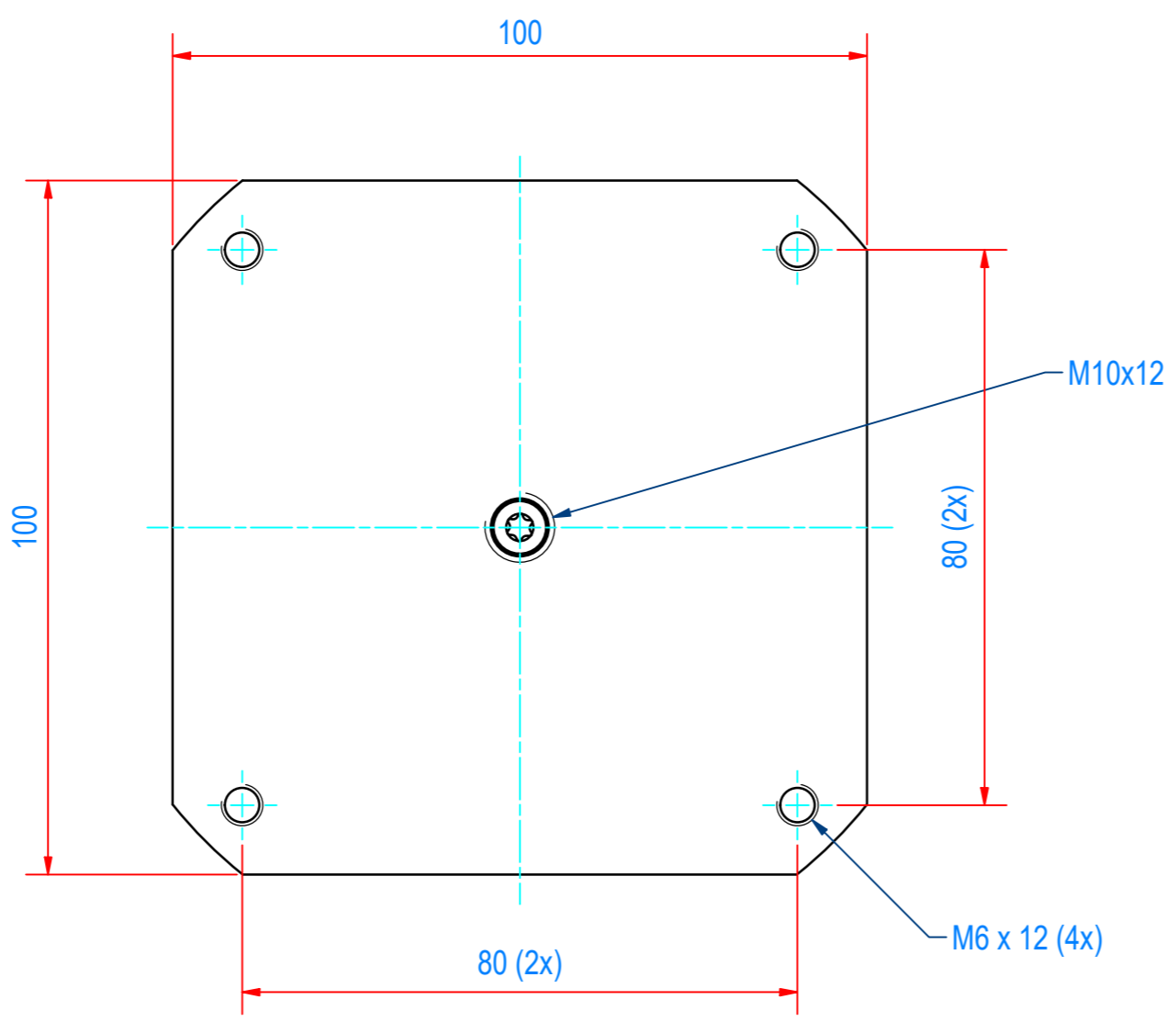