

REV	DATE	BY	DESCRIPTION
-	8-4-2013	PB	NEW VAULT, NEW REVISION. NOTHING CHANGED. OLD REV WAS D
A	24-6-2015	AvD	E0034158 WAS A190523 (REDESIGN, HEIGHT 104 WAS 94)
B	1-7-2015	AvD	O-RING DELETED FROM BOTTOM

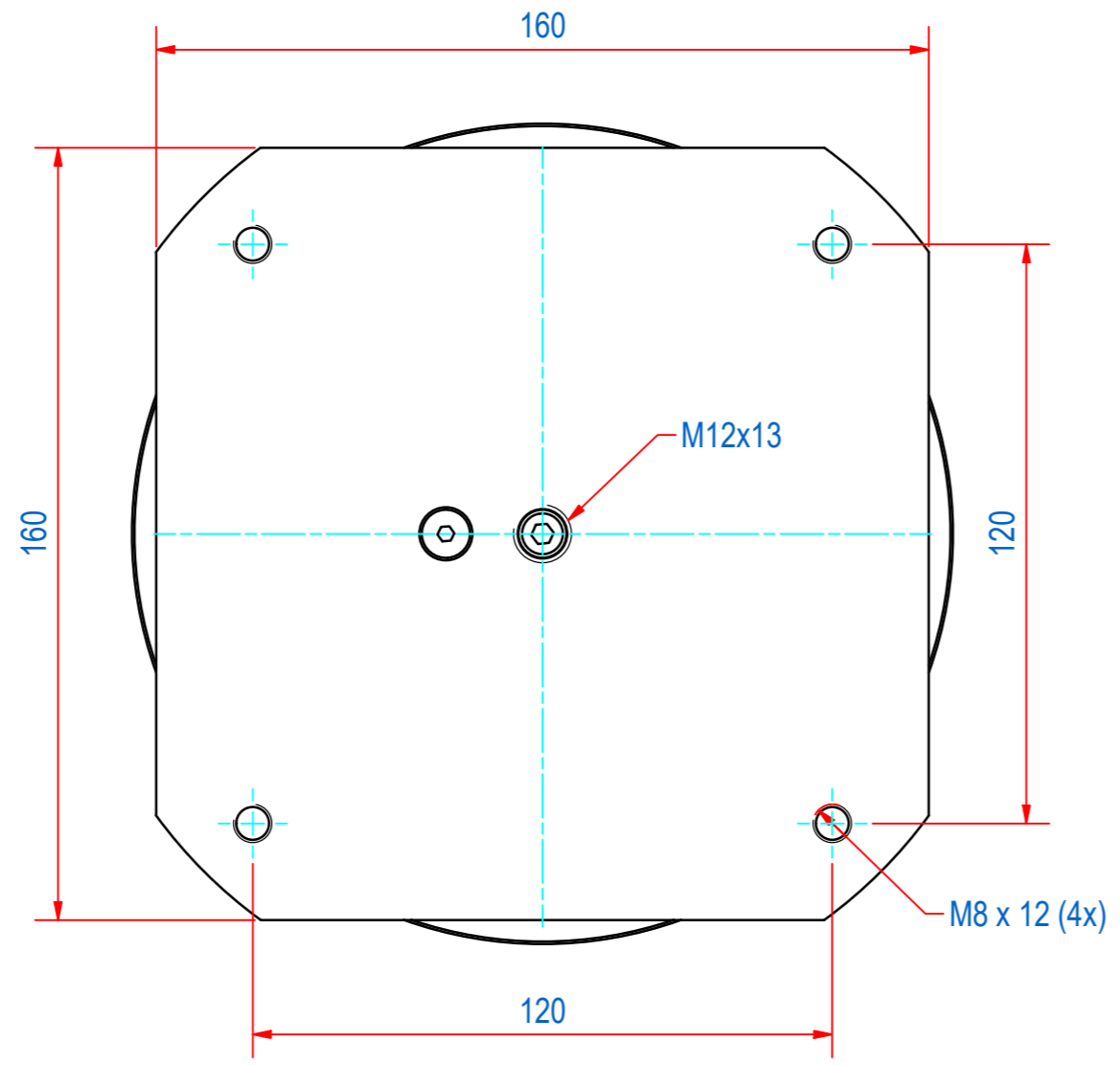

USE PUN-E-8x1 HOSE

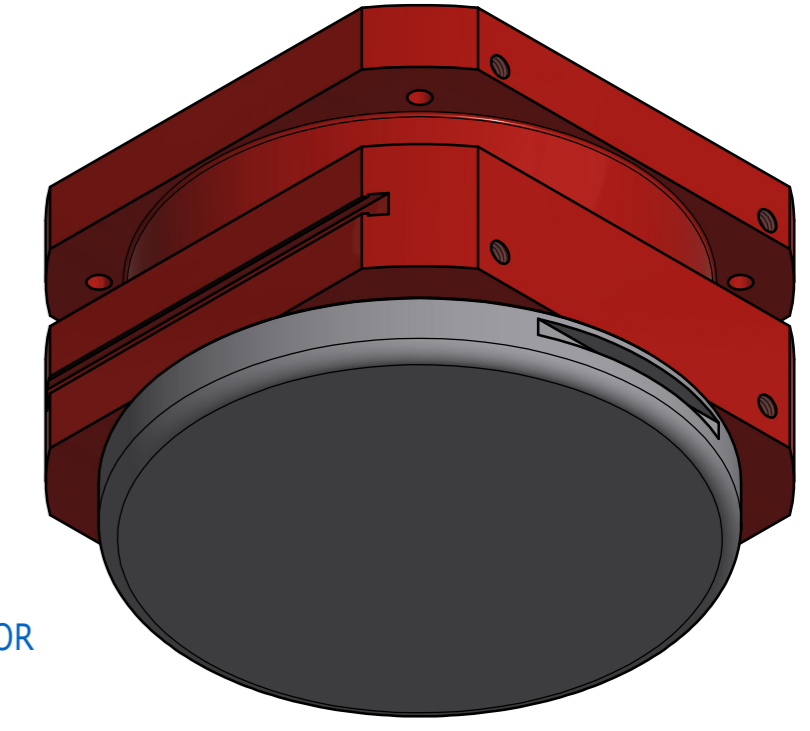
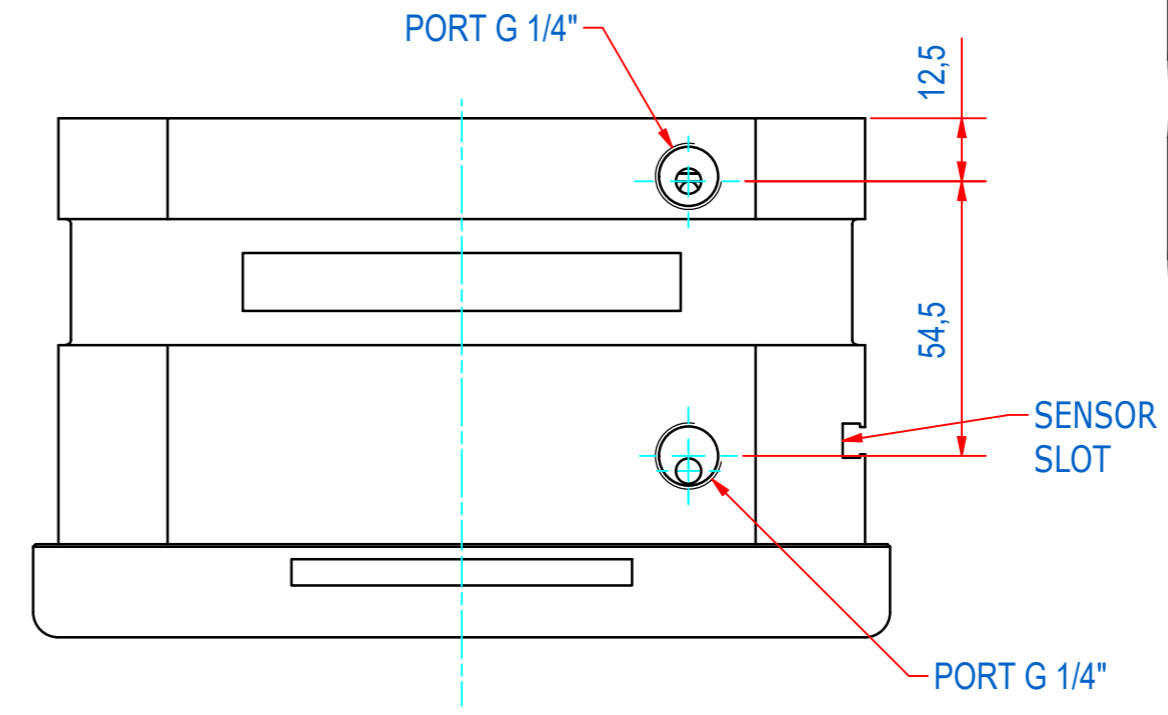
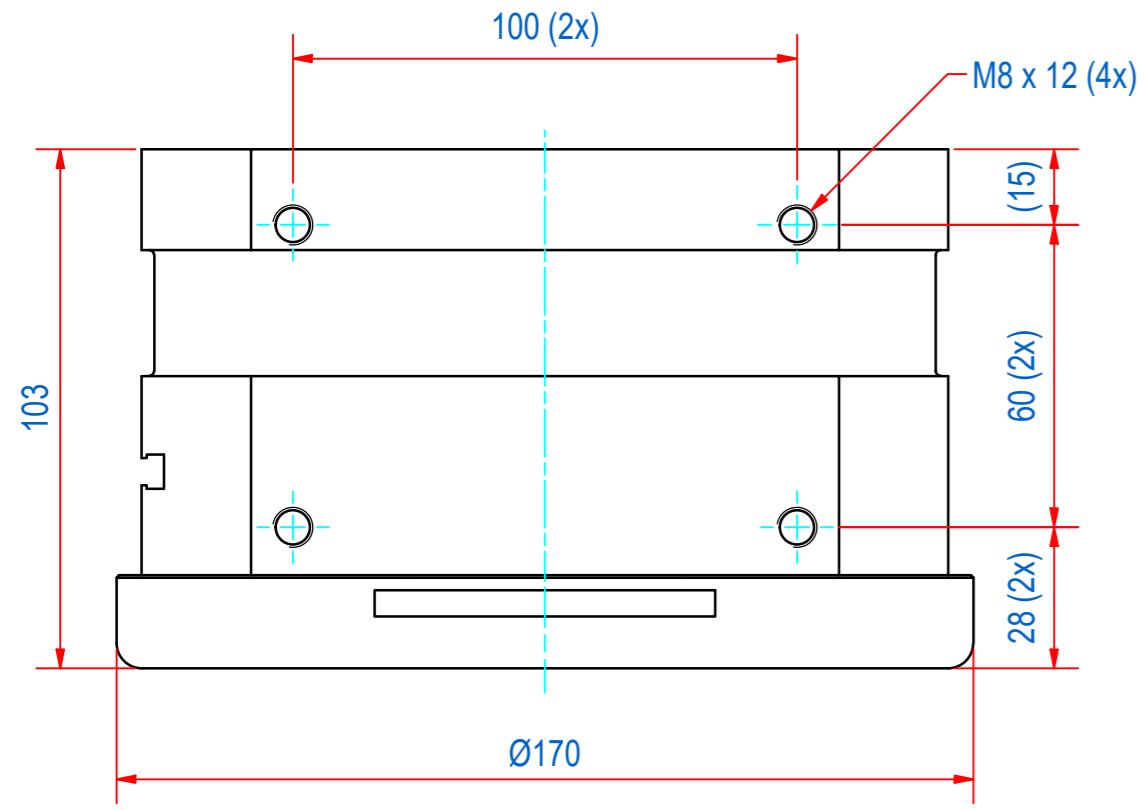
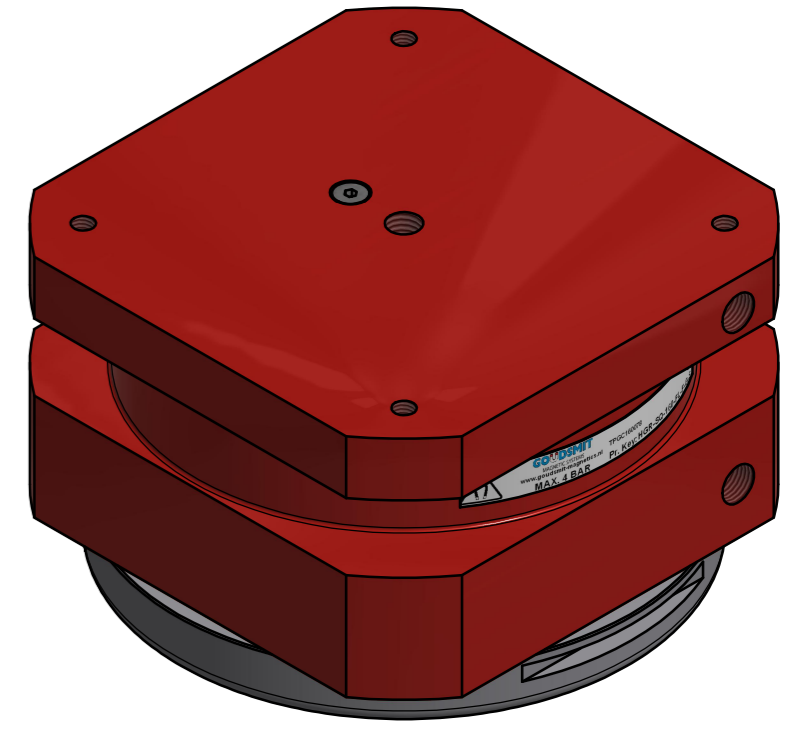

ITEM	QTY	PART NUMBER	DESCRIPTION	Dimensions
2	1	E0038029	STICKER TPGC160078	
1	1	E0034158	MOUNTING ASSY TPGC160	
RAW MAT.	Quantity	Material Number	Material Description	Length (mm) Width (mm)
	1			
Sheet: A2		Extra info: MAGNETIC GRIPPER		General tolerance: ISO 2768 - mK
Drawn: PB		Weight (kg): 5.8		Drawn according: ISO268; ISO1101; ISO2553
Date: 11-7-2019		Source: MC-C		Status: Standard
Spare part: False		Quick search: TPGC160		Customer reference number:
Description: HGR-SQ-160-FL-F-G-S		© All rights reserved. Reproduction is not permitted without written permission of GOUDSMIT Magnetic Systems BV		Document number: TPGC160078 Doc.Rev: B
				Part number: TPGC160078 Rev: B