

3	2	1		
DOC.NR.	REV	DATE	BY	DESCRIPTION
TPMV040028	-	9-10-2013	BS	NEW VAULT, NOTHING CHANGED, IS EQUAL TO OLD REVISION B

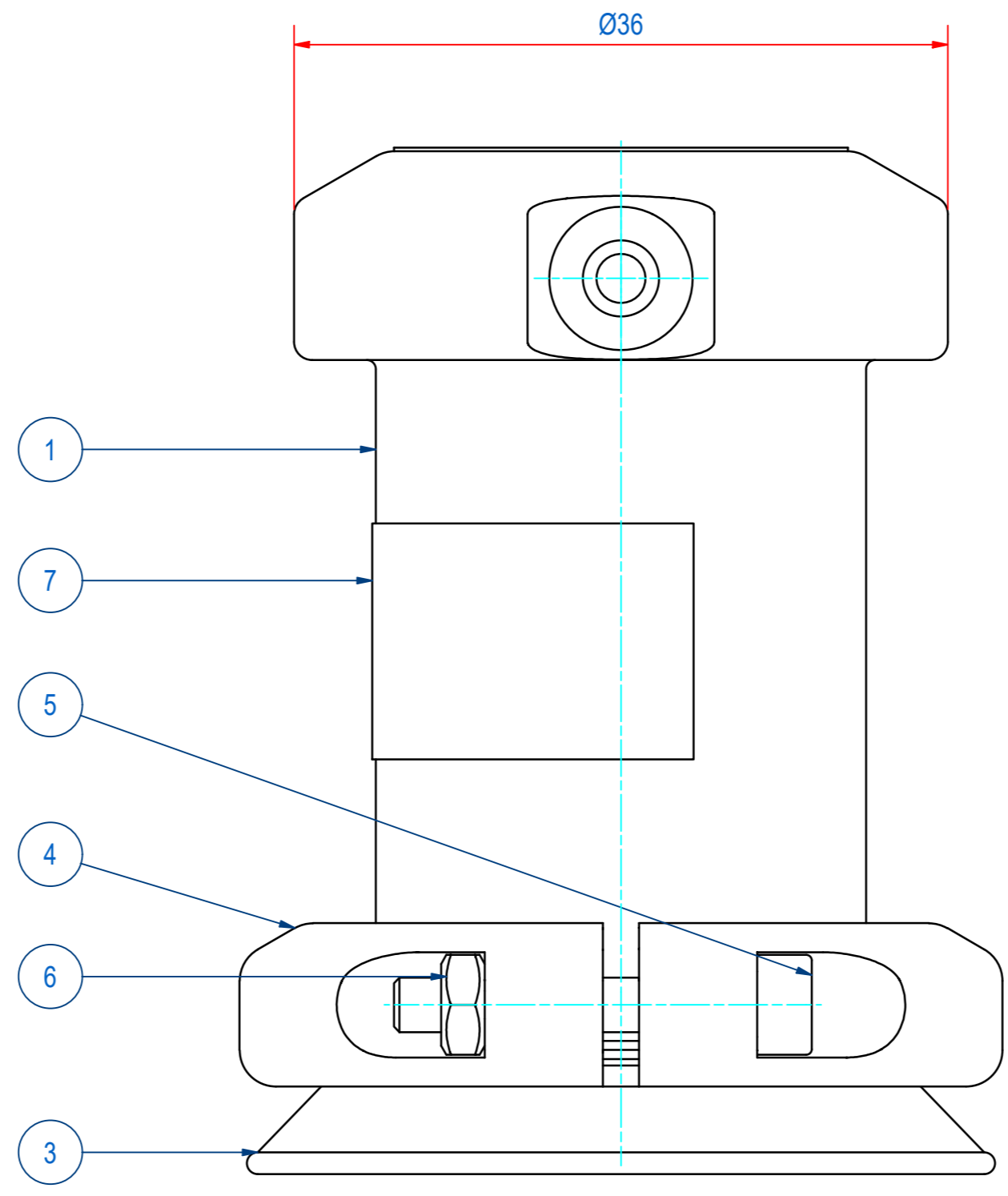
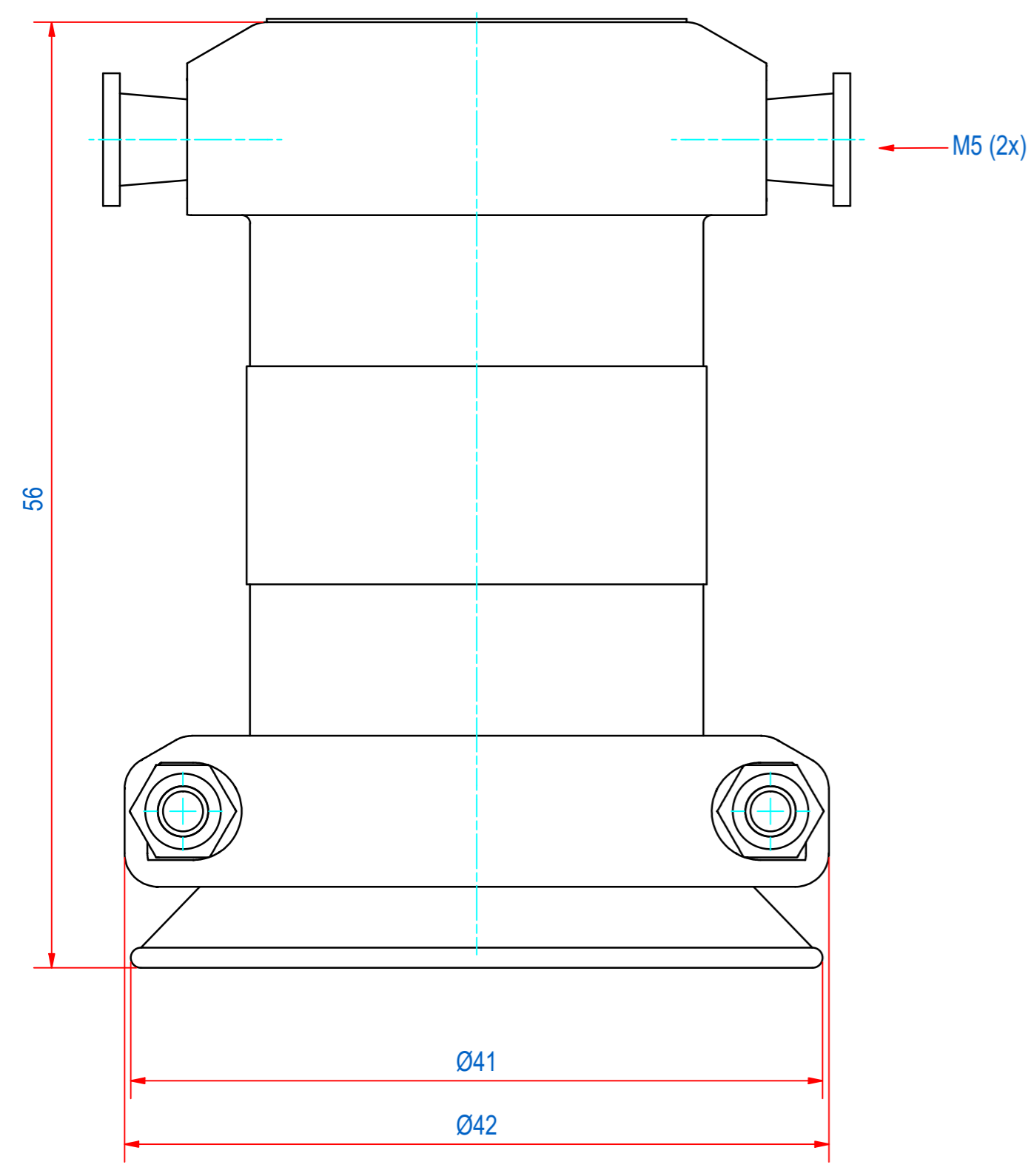
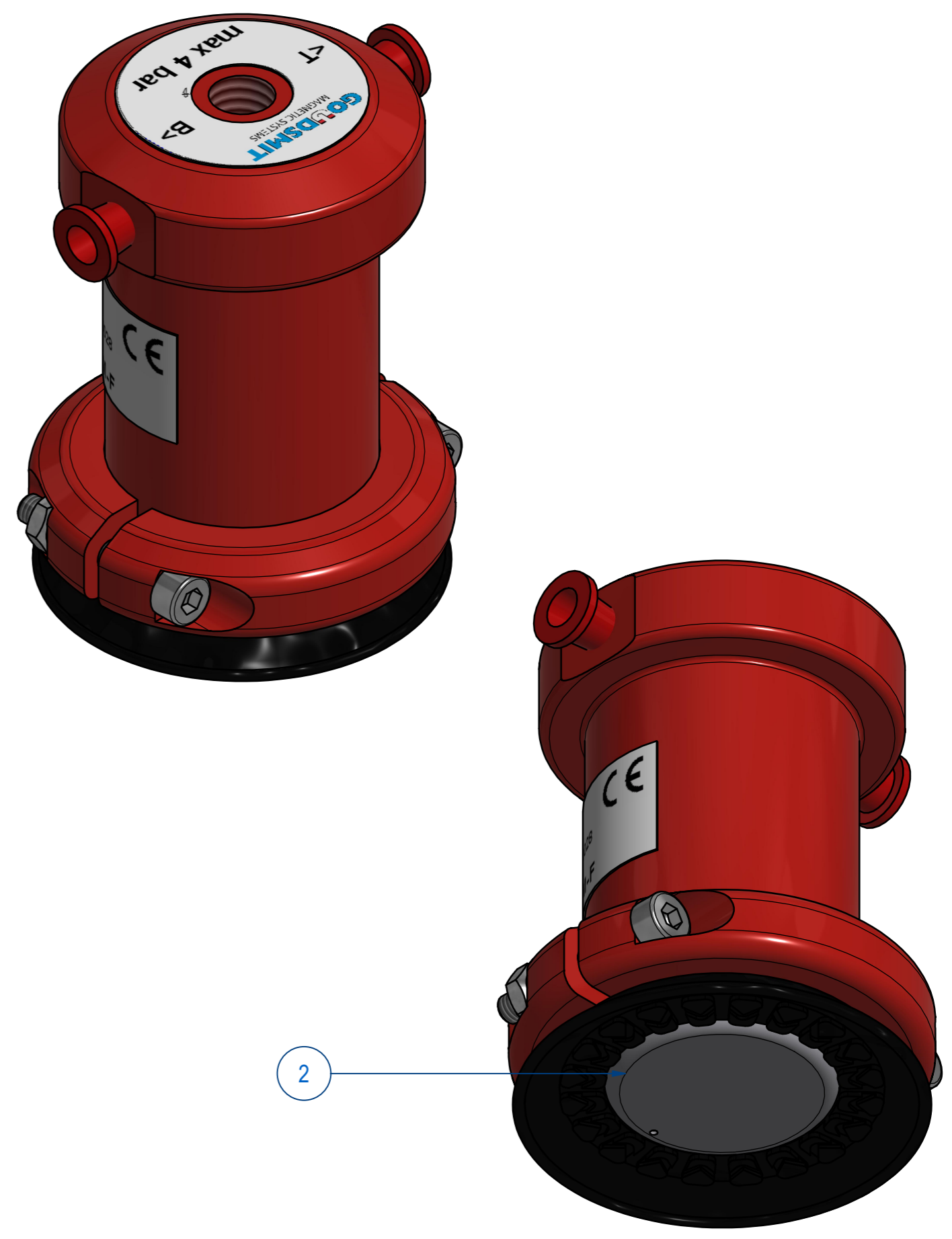
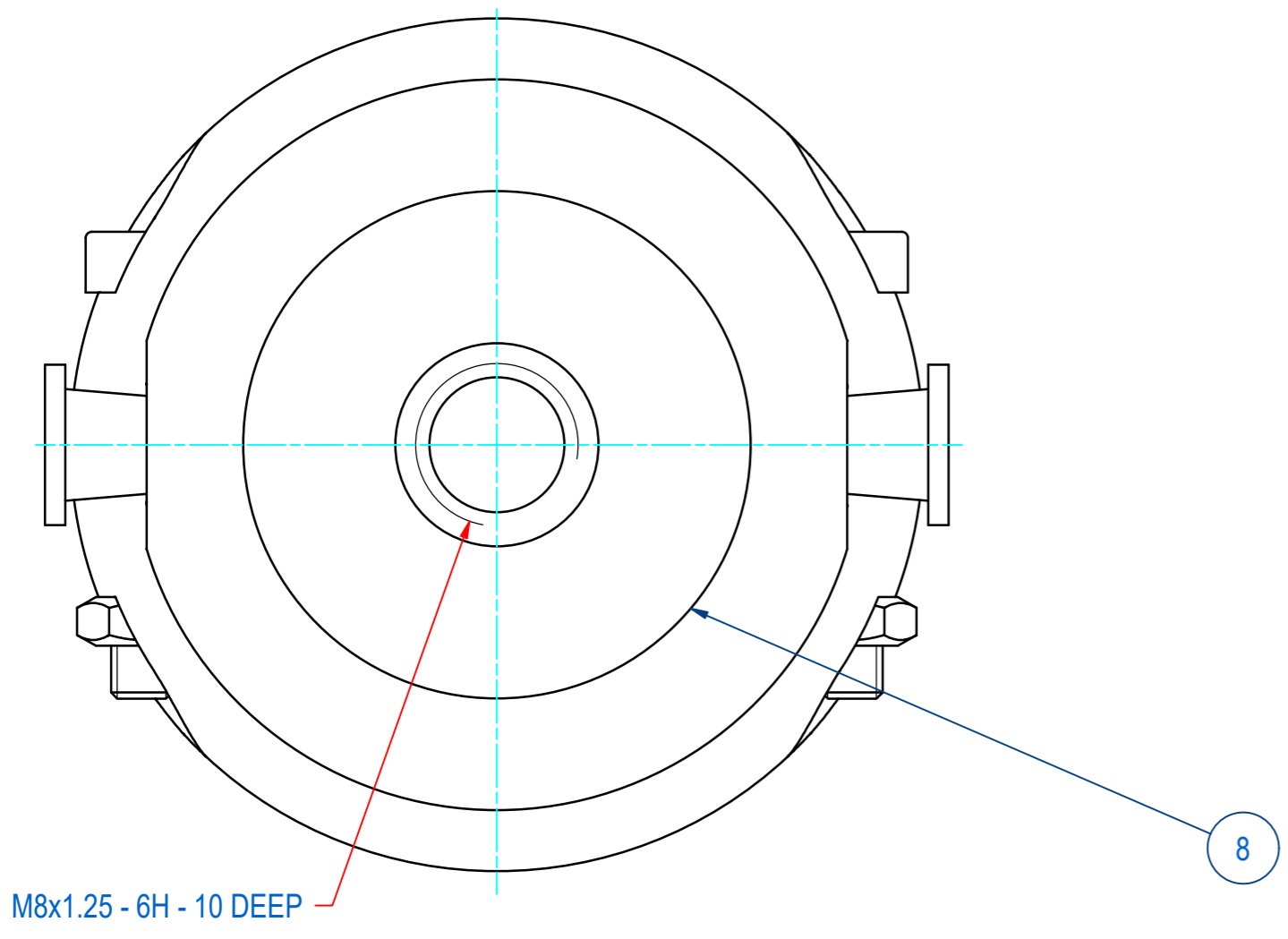

ITEM	QTY	PART NUMBER	DESCRIPTION	Dimensions
8	1	E0038131	STICKER TOP D40 d = 25 mm	
7	1	E0037940	STICKER TPMV040028	
6	2	60.0100003	NUT, HEX M3 - St8 Zn	M3
5	2	51.0103020	SCREW, HEX SH M3x20-St8.8Zn	M3 x 20
4	2	M35641	CLEAT TP040	
3	1	M35639	HGC-SPARE-VACUUM PAD TPMV040	
2	1	M35648	HGR-SPARE-BOTTOM COVER TP040 VAC.	
1	1	M35647	MOUNTING ASSY TP--040028	

RAW MAT.	Quantity	Material Number	Material Description	Length (mm)	Width (mm)
⊕	Sheet: A2	Extra info:	General tolerance: ISO 2768 - mK		
Drawn: AJA	Weight (kg): 0,10		Drawn according: ISO286; ISO1101; ISO2553		
Date: 9-12-2004			Status: Standard		
Spare part: False	Source: MC-C		Customer reference number:		
Quick search: TPMV040			Document number: TPMV040028	Doc.Rev:	
Description: HGC-RO-040-VR-R-M-F			Part number: TPMV040028	Rev:	