

3	2	1		
DOC.NR.	REV	DATE	BY	DESCRIPTION
TPMV100028	-	18-12-2013	BS	NEW VAULT, NOTHING CHANGED, IS EQUAL TO OLD REVISION B

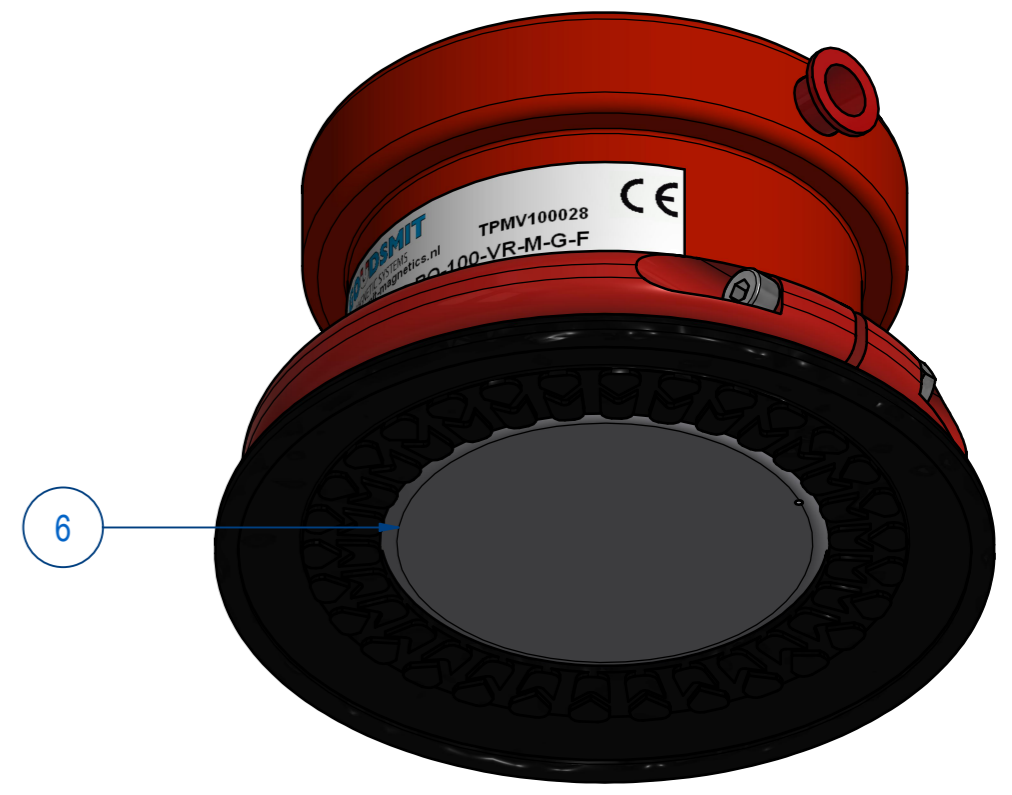
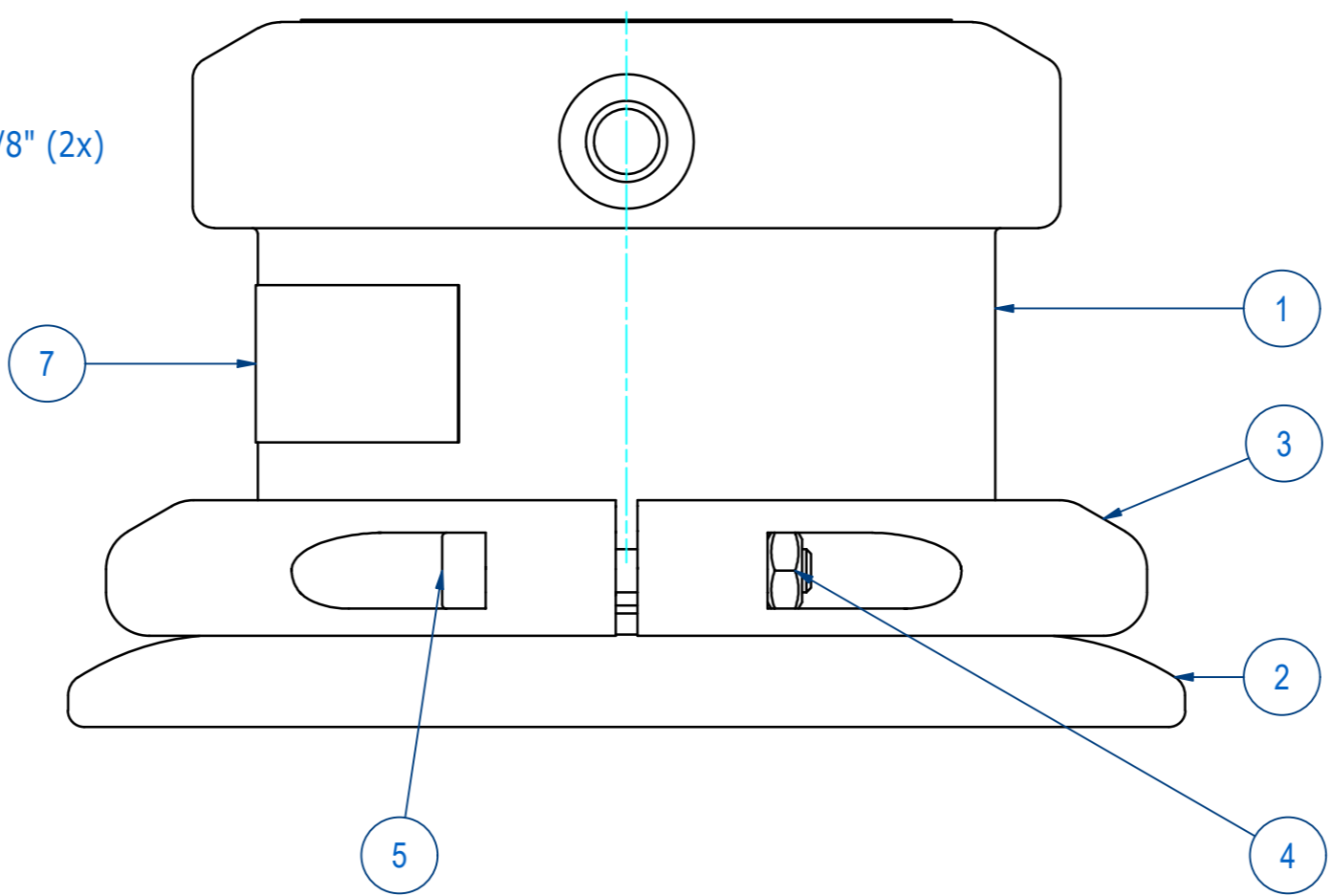
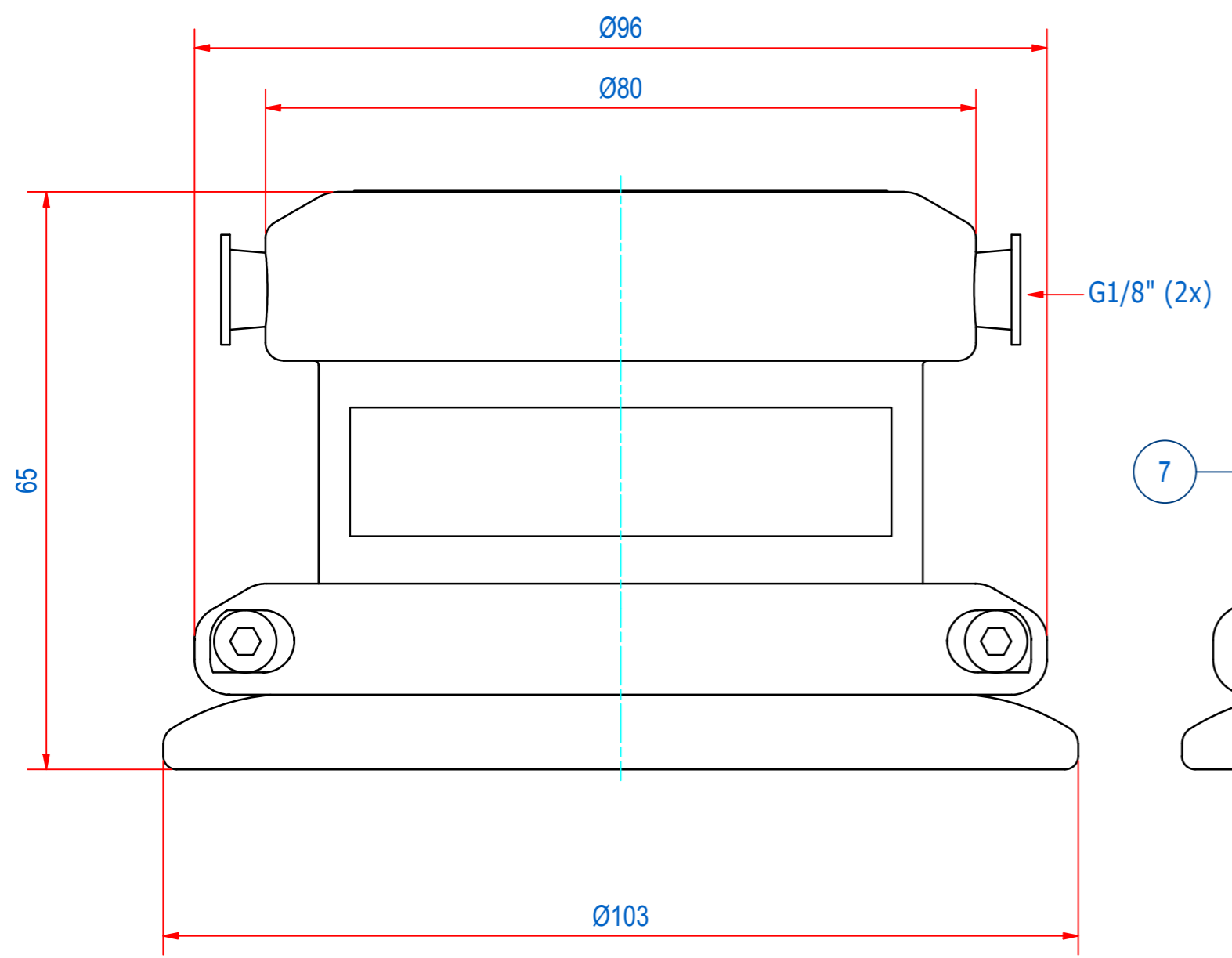
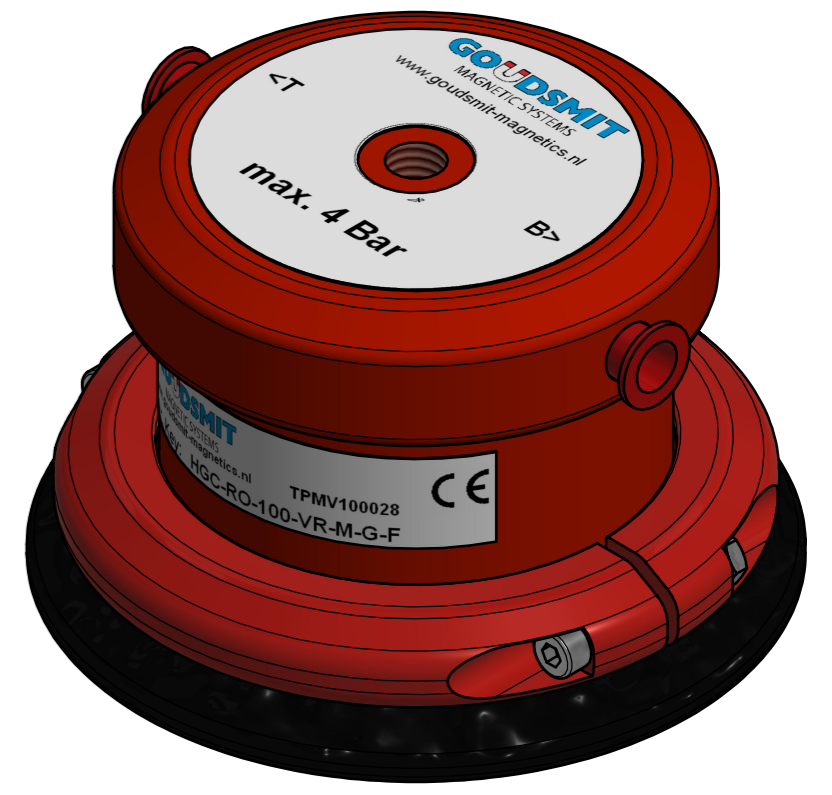
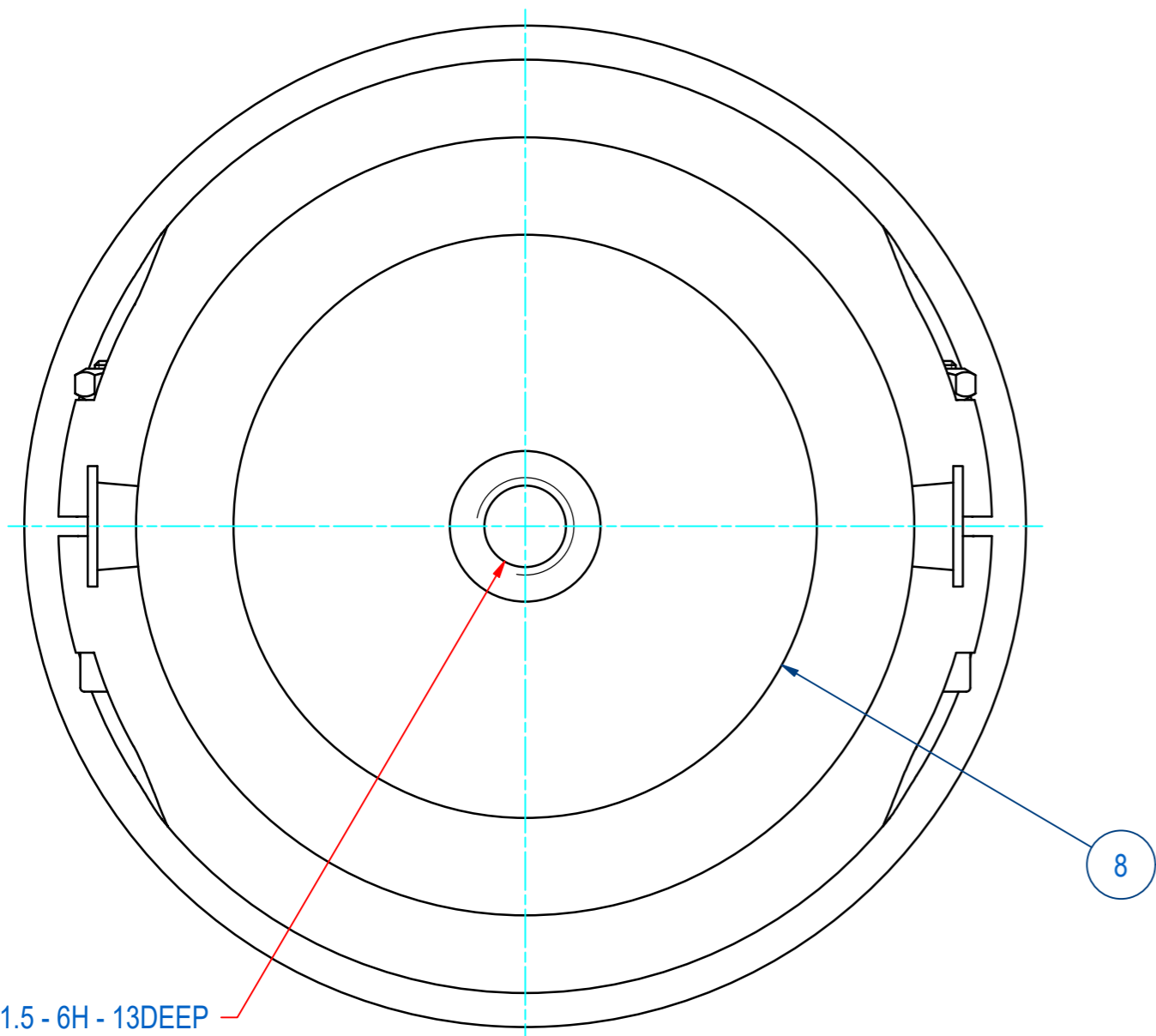

ITEM	QTY	PART NUMBER	DESCRIPTION	Dimensions
8	1	E0038135	STICKER TOP_D100 d = 60 mm	
7	1	E0037979	STICKER TPMV100028	
6	1	M35636	BOTTOM COVER TP100 VACUUM HOLE	
5	2	51.0104030	SCREW, HEX SH M4x30-St8.8Zn	M4 x 30
4	2	60.0100004	NUT, HEX M4 - St8 Zn	M4
3	2	M35605	CLEAT TP100	
2	1	M60074	HGC-SPARE-VACUUM PAD DIA 100	
1	1	M35618	ASSY TP--100028	

RAW MAT.	Quantity	Material Number	Material Description	Length (mm)	Width (mm)
⊕	1				

Sheet: A2	Extra info:	General tolerance: ISO 2768 - mK
Drawn: BS	Weight (kg): 0,69	Drawn according: ISO286; ISO1101; ISO2553
Date: 17-12-2013		Status: Standard
Spare part: False	Source: MC-C	Customer reference number:
Quick search: TPMV100		
Description: HGC-RO-100-VR-M-G-F	Document number: TPMV100028	Doc.Rev: -
	Part number: TPMV100028	Rev: -