

REV	DATE	BY	DESCRIPTION
-	9-10-2018	GS	ORIGINAL DRAWING; REF. TPSP000009 / 011
A	16-12-2022	LH	SOURCE CODE AND STICKER ADDED

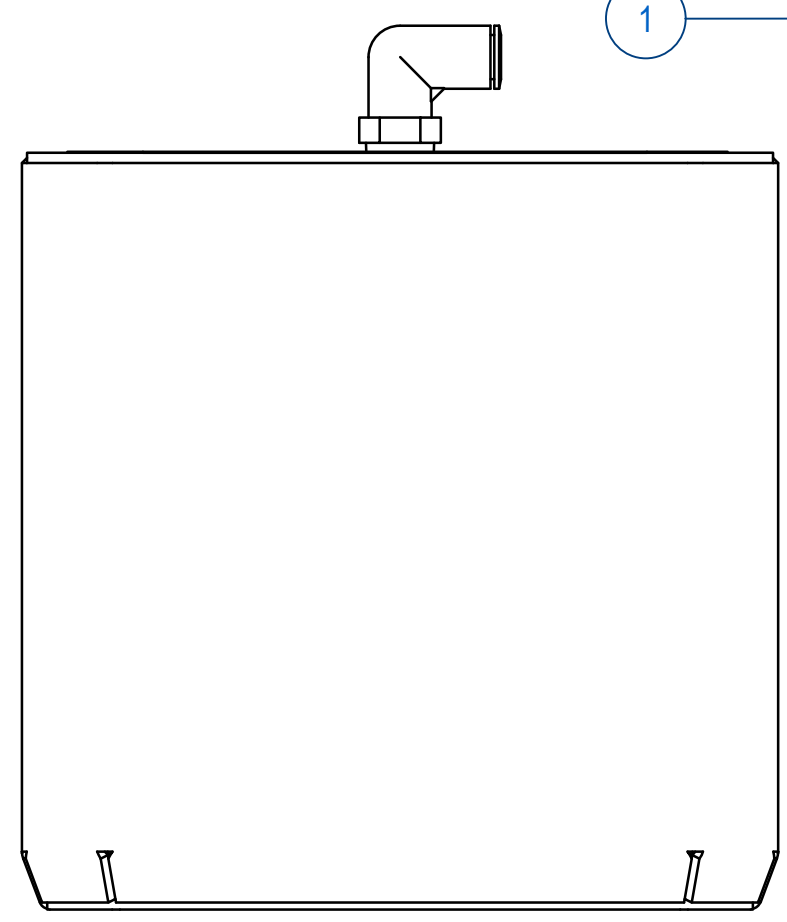
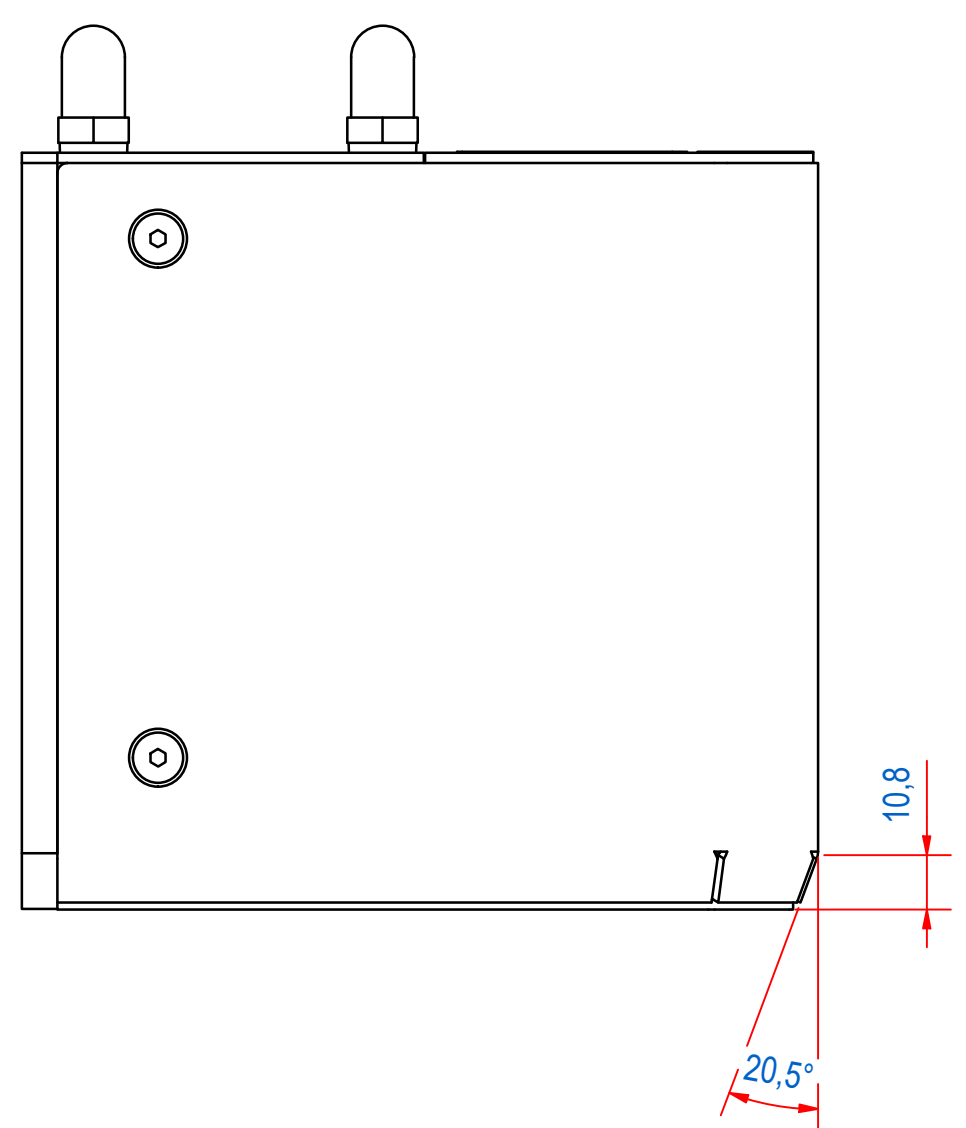
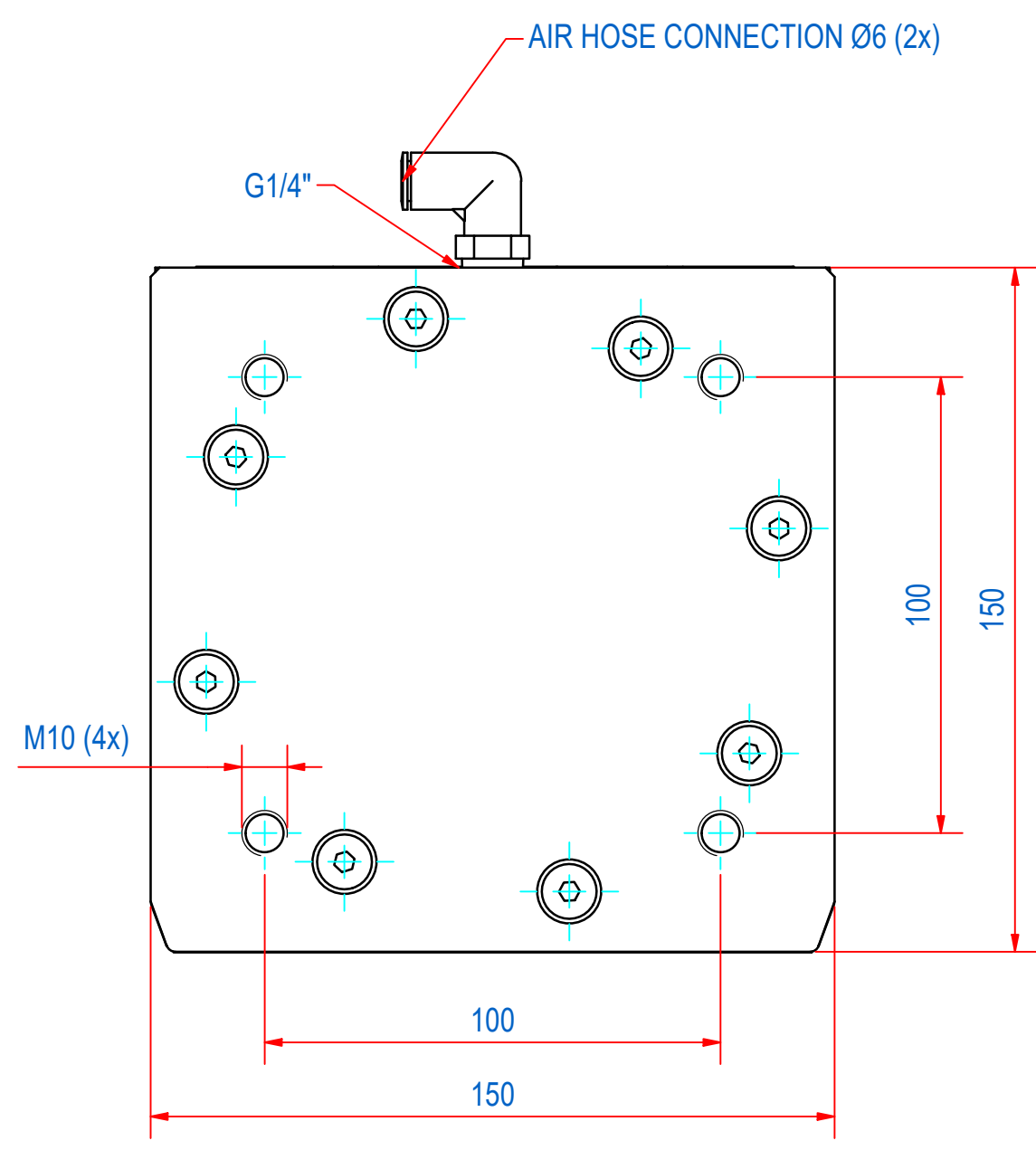
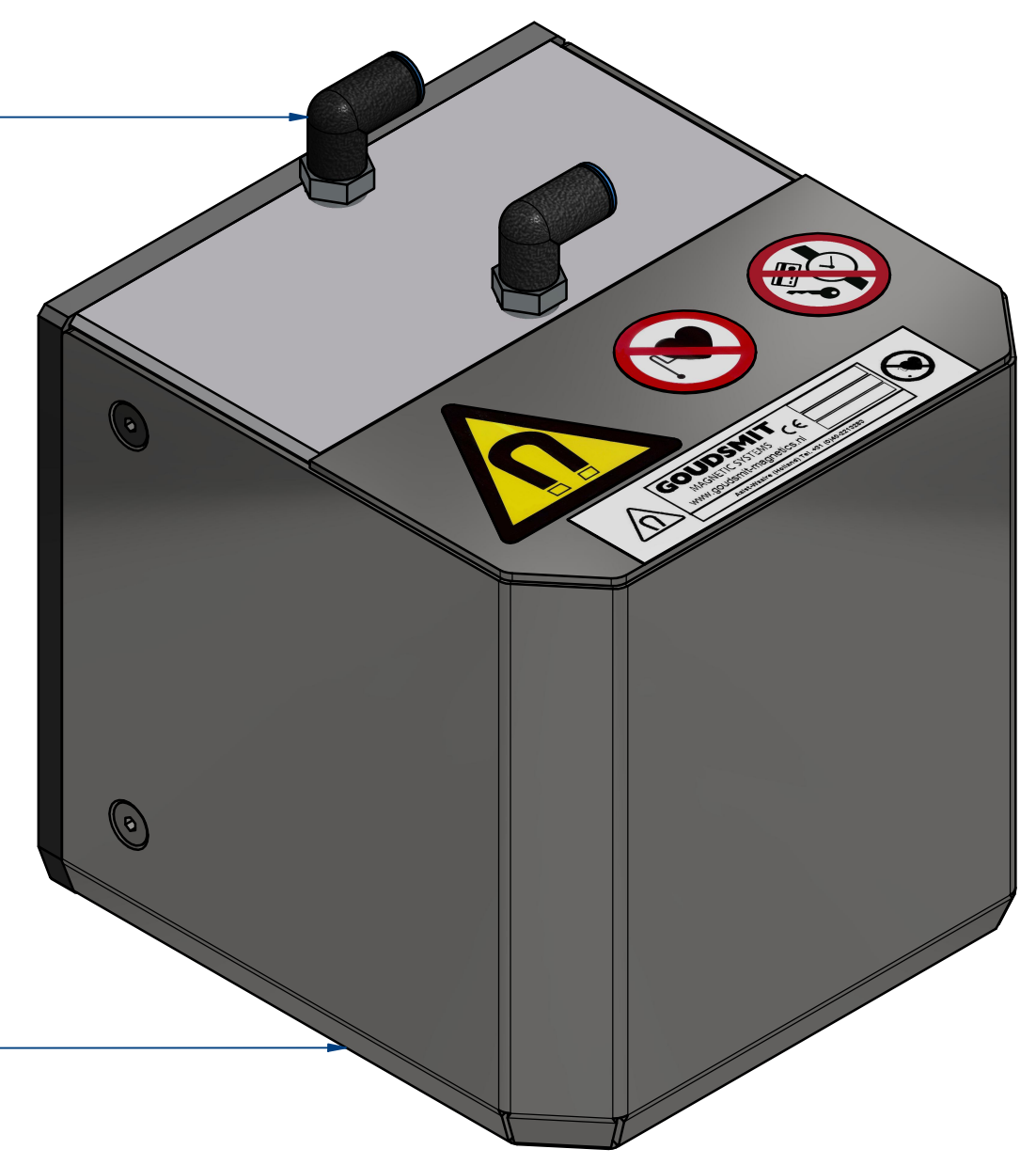
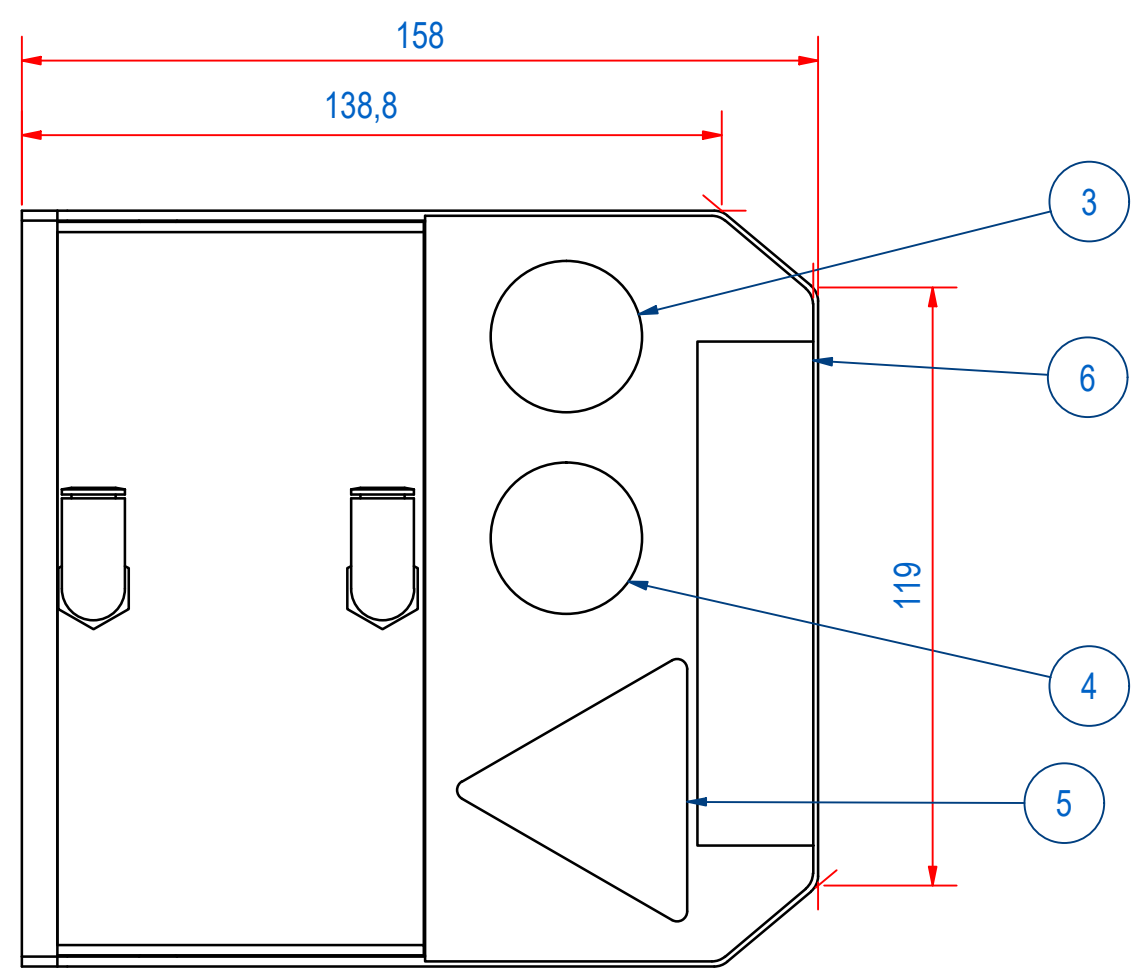

ITEM	QTY	PART NUMBER	DESCRIPTION	Dimensions
6	1	P190398	STICKER GOUDSMIT 100X23	
5	1	1000.20030	STICKER MAGNETIC FIELD 50mm	
4	1	1000.20020	STICKER PACEMAKER FORBID. D=30	
3	1	1000.20019	STICKER ARTICLES FORBID D30	
2	2	83.2500012	PUSH-IN L-FITTING QSL-1/4-6-100	
1	1	E0102979	HSS-PNEUMATIC SHEET SEPARATOR	

RAW MAT.	Quantity	Material Number	Material Description	Length (mm)	Width (mm)
	1				

Sheet: A2	Extra info: STRAIGHT FRONT SIMRIT PISTON	General tolerance: ISO 2768 - mK
Drawn: GS	Weight (kg): 8,9	Drawn according: ISO268; ISO1101; ISO2553
Date: 8-10-2018	Source: MC-C	Status: Standard
Spare part: False	Quick search: TPSP150	Customer reference number:
Description: HSS-N-PA-150x158-0150-C		Document number: TPSP000017 Doc.Rev: A
		Part number: TPSP000017 Rev: A