

REV	DATE	BY	DESCRIPTION
-	9-10-2018	GS	REFERENCE DRAWING TPSP000012
A	16-12-2022	LH	STICKER SOURCE CODE ADDED, DOCUMENT NAMES UPDATED

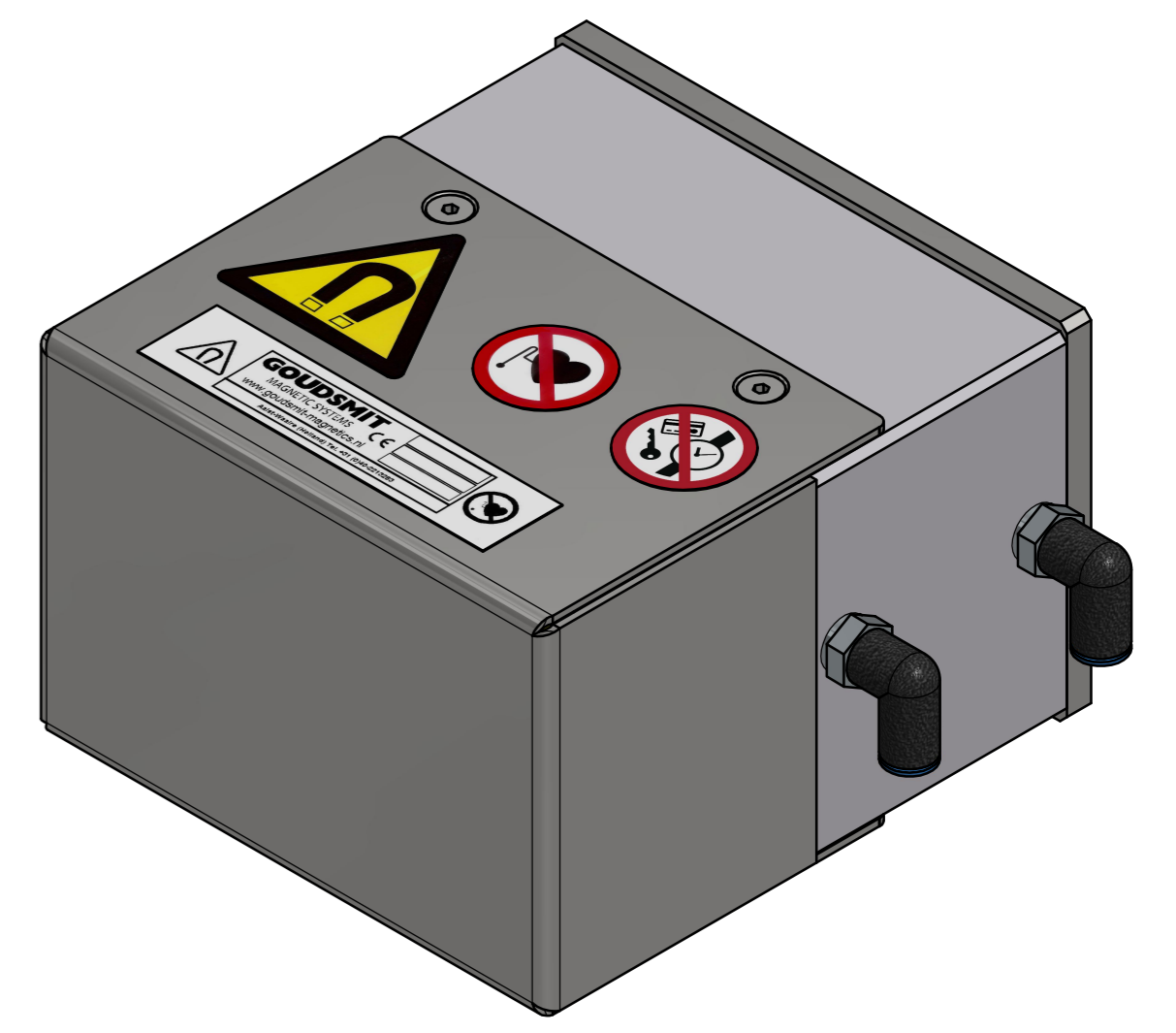
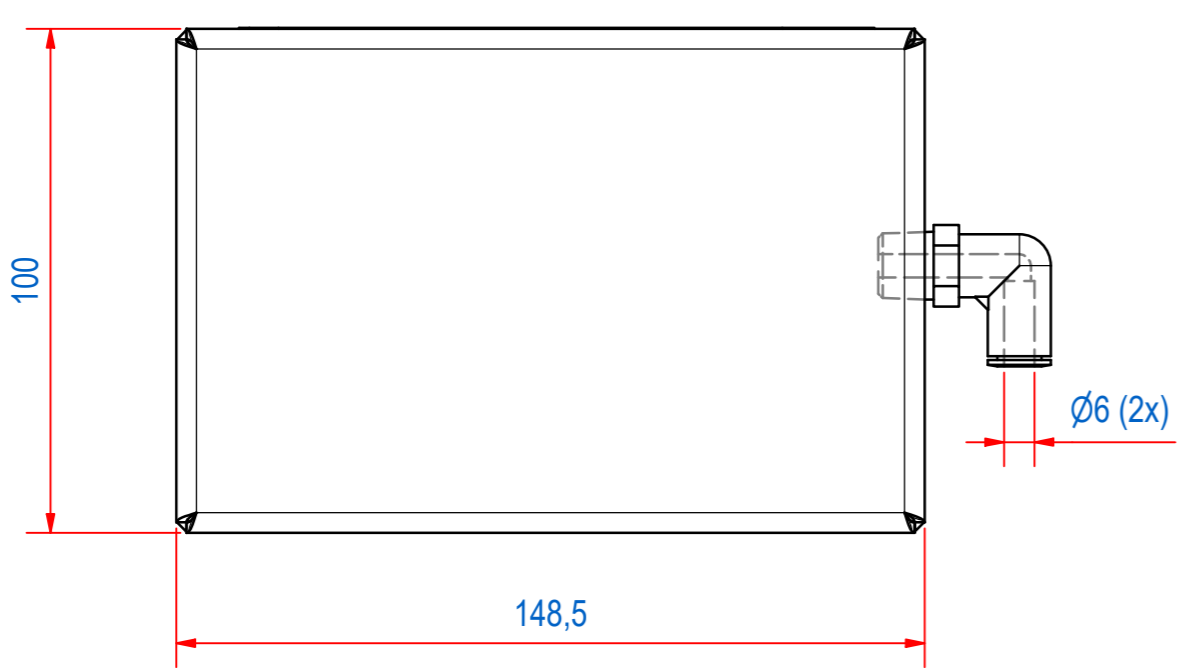
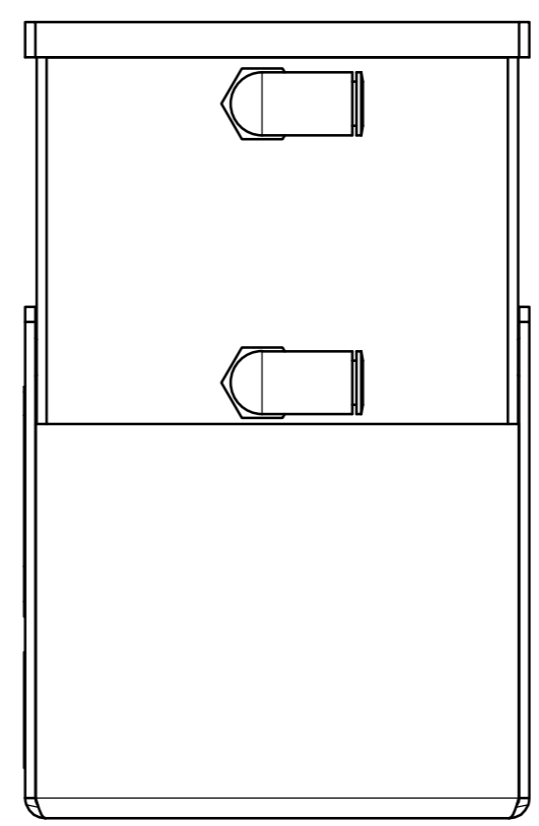
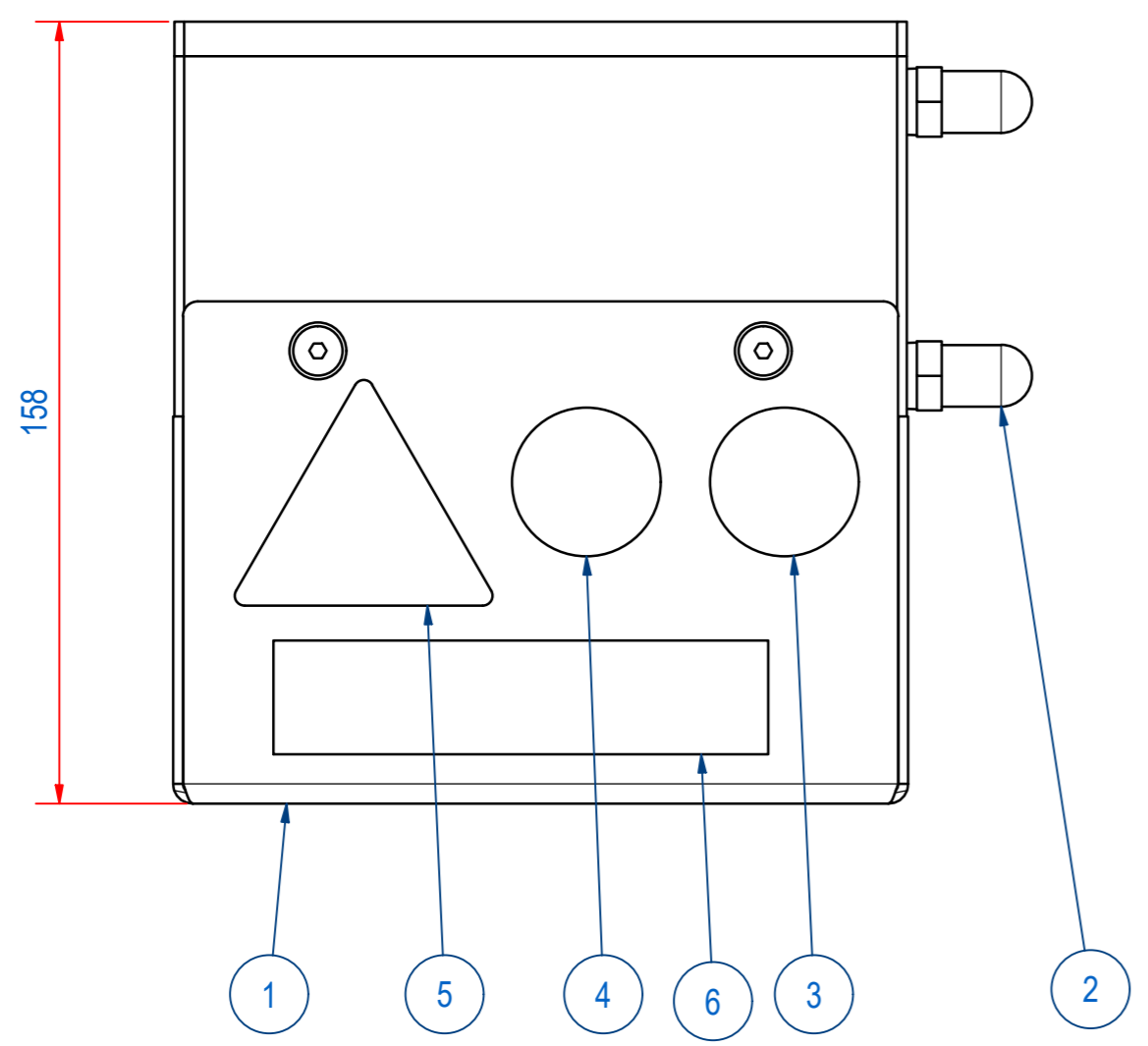
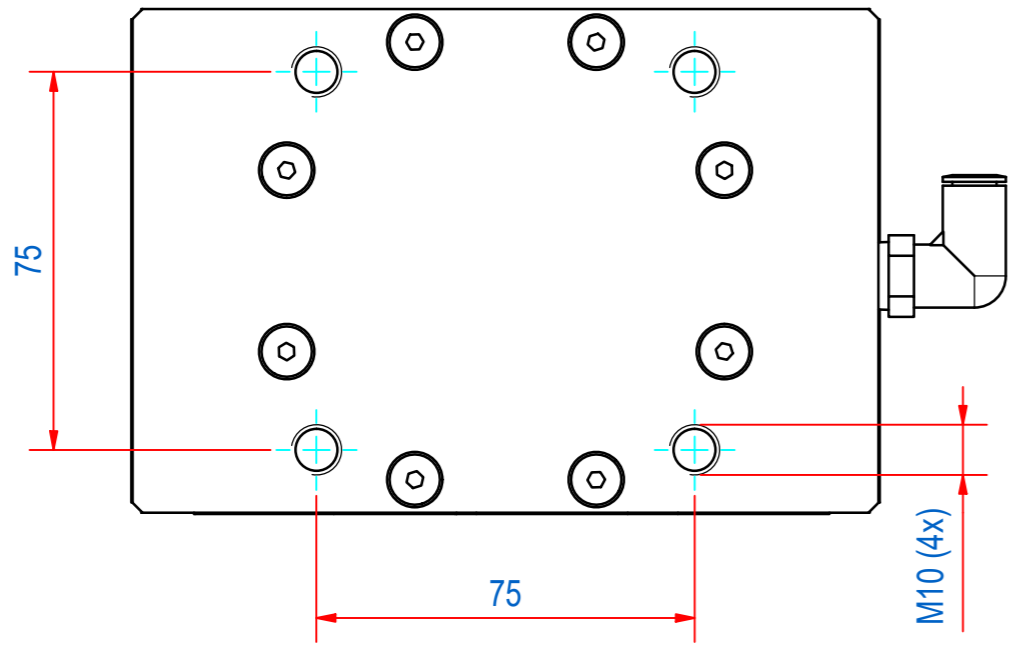

ITEM	QTY	PART NUMBER	DESCRIPTION	Dimensions
6	1	P190398	STICKER GOUDSMIT 100X23	
5	1	1000.20030	STICKER MAGNETIC FIELD 50mm	
4	1	1000.20020	STICKER PACEMAKER FORBID. D=30	
3	1	1000.20019	STICKER ARTICLES FORBID D30	
2	2	83.2500012	PUSH-IN L-FITTING QSL-1/4-6-100	
1	1	E0103080	HSS-PNEUMATIC SHEET SEPARATOR	

RAW MAT.	Quantity	Material Number	Material Description	Length (mm)	Width (mm)
⊕	1				

Sheet:	A2	Extra info:	SIMRIT PISTON Ø80	General tolerance:	ISO 2768 - mK
Drawn:	GS	Weight (kg):	6,1	Drawn according:	ISO268; ISO1101; ISO2553
Date:	9-10-2018	Status:	Standard	Customer reference number:	
Spare part:	False	Source:	MC-C	Document number:	TPSP000018
Quick search:	TPSP150	 <small>© All rights reserved. Reproduction is not permitted without written permission of GOUDSMIT Magnetic Systems BV</small>		Doc.Rev:	A
Description:	HSS-N-PA-150x158-0100-B			Part number:	TPSP000018
				Rev:	A